

Declaration of Conformity - For Recreational Craft Propulsion Engines with the Requirements of Directive 94/25/EC as amended by Directive 2003/44/EC

Name of engine manufacturer: Mercury Marine		
Address: W6250 Pioneer Road, P.O. Box 1939		
Town: Fond du Lac, WI	Post Code: 54936-1939	Country: USA

Name of Authorized Representative: Brunswick Marine in EMEA Inc.		
Address: Parc Industriel de Petit-Rechain		
Town: Verviers	Post Code: B-4800	Country: Belgium

Name of Notified Body for exhaust emission assessment: Det Norske Veritas AS			
Address: Veritasveien 1			
Town: Hovik	Post Code: 1322	Country: Norway	ID Number: 0575

Conformity assessment module used for exhaust emissions:	<input type="checkbox"/> B +C	<input type="checkbox"/> B +D	<input type="checkbox"/> B +E	<input type="checkbox"/> B +F	<input type="checkbox"/> G	<input checked="" type="checkbox"/> H
Other Community Directives applied: Electromagnetic Compatibility Directive 2004/108/EC						

Description of Engines and Essential Requirements

Engine Type	Fuel Type	Combustion Cycle
<input type="checkbox"/> Z or sterndrive without integral exhaust	<input type="checkbox"/> Diesel	<input checked="" type="checkbox"/> 2 stroke
<input checked="" type="checkbox"/> Inboard engine	<input checked="" type="checkbox"/> Petrol	<input type="checkbox"/> 4 stroke

Identification of Engines Covered by This Declaration of Conformity

Name of engine family	Unique engine identification number(s) or engine family code(s); starting serial number	EC Type-examination certificate or type-approval certificate number
200 HP Sport-Jet	0E433154	RCD-H-2 Rev 4

Essential requirements	Standards	Other normative document/ method	Technical file	Please specify in more detail (* = mandatory standard)
Annex 1.B—Exhaust Emissions				
B.1 engine identification	<input type="checkbox"/>	<input type="checkbox"/>	<input checked="" type="checkbox"/>	
B.2 exhaust emission requirements	<input checked="" type="checkbox"/> *	<input type="checkbox"/>	<input type="checkbox"/>	* EN ISO 8178-1:1996
B.3 durability	<input type="checkbox"/>	<input type="checkbox"/>	<input checked="" type="checkbox"/>	
B.4 owner's manual	<input checked="" type="checkbox"/>	<input type="checkbox"/>	<input type="checkbox"/>	ISO 8665: 2006
Annex 1.C—Noise Emissions	see Declaration of Conformity of the craft in which the engine(s) has (have) been installed			

This declaration of conformity is issued under the sole responsibility of the manufacturer. I declare on behalf of the engine manufacturer that the engine(s) will meet the exhaust emission requirements of Directive 94/25/EC as amended by Directive 2003/44/EC when installed in a recreational craft, in accordance with the engine manufacturer's supplied instructions and that this (these) engine(s) must not be put into service until the recreational craft into which it is (they are) to be installed has been declared in conformity with the relevant provisions of the above mentioned Directives.

Name / function:

Mark D. Schwabero, President
Mercury Marine



Date and place of issue:

September 04, 2012
Fond du Lac, Wisconsin, USA

Welcome

You have selected one of the finest jet drives available. It incorporates numerous design features to ensure operating ease and durability.

With proper care and maintenance of this product, you will thoroughly enjoy using it for many boating seasons. To ensure maximum performance and carefree use, thoroughly read this manual, which contains specific instructions for using and maintaining your product. Keep this manual with the product for ready reference whenever you are on the water.

Thank you for purchasing one of our products. We sincerely hope your boating will be pleasant.

Mercury Marine

EPA Emissions Regulations

Jet Drives manufactured by Mercury Marine in the United States are certified to the United States Environmental Protection Agency as conforming to the requirements of the regulations for the control of air pollution from new Jet Drive motors. This certification is contingent on certain adjustments being set to factory standards. For this reason, the factory procedure for servicing the product must be strictly followed and, wherever practicable, returned to the original intent of the design. Maintenance, replacement, or repair of the emission control devices and systems may be performed by any marine engine repair establishment or individual.

Engines are labeled with an Emission Control Information decal as permanent evidence of EPA certification.

WARNING

The engine exhaust from this product contains chemicals known to the state of California to cause cancer, birth defects or other reproductive harm.

Warranty Message

The product you have purchased comes with a limited warranty from Mercury Marine. The terms of the warranty are set forth in the **Warranty Information** section of this manual. The warranty statement contains a description of what is covered, what is not covered, the duration of coverage, how to best obtain warranty coverage, important disclaimers and limitations of damages, and other related information. Please review this important information.

The description and specifications contained herein were in effect at the time this manual was approved for printing. Mercury Marine, whose policy is one of continued improvement, reserves the right to discontinue models at any time, to change specifications, designs, methods, or procedures without notice and without incurring obligation.

Mercury Marine, Fond du Lac, Wisconsin U.S.A.

Mercury Premier Service

Mercury evaluates the service performance of its dealers and assigns its highest rating of Mercury Premier to those demonstrating an exceptional commitment to service.

Earning a Mercury Premier Service rating means a dealer:

- Achieves a high 12-month service Customer Satisfaction Index (CSI) score for warranty service.
- Possesses all of the necessary service tools, test equipment, manuals, and parts books.
- Employs at least one certified or master technician.
- Provides timely service for all Mercury Marine customers.
- Offers extended service hours and mobile service, when appropriate.
- Uses, displays, and stocks an adequate inventory of genuine Mercury Precision Parts.
- Offers a clean, neat shop with well-organized tools and service literature.

Copyright and Trademark Information

© MERCURY MARINE. All rights reserved. Reproduction in whole or in part without permission is prohibited.

Alpha, Axius, Bravo One, Bravo Two, Bravo Three, Circle M with Waves Logo, K-planes, Mariner, MerCathode, MerCruiser, Mercury, Mercury with Waves Logo, Mercury Marine, Mercury Precision Parts, Mercury Propellers, Mercury Racing, MotorGuide, OptiMax, Quicksilver, SeaCore, Skyhook, SmartCraft, Sport-Jet, Verado, VesselView, Zero Effort, Zeus, #1 On the Water and We're Driven to Win are registered trademarks of Brunswick Corporation. Pro XS is a trademark of Brunswick Corporation. Mercury Product Protection is a registered service mark of Brunswick Corporation.

WARRANTY INFORMATION

Warranty Registration United States and Canada.....	1
Transfer of Warranty United States and Canada.....	1
Transfer of Mercury Product Protection (Extended Service Coverage) Plan United States and Canada.....	2
3 Year Limited Warranty Against Corrosion.....	2
Warranty Coverage and Exclusions.....	4
U.S. EPA Emissions Limited Warranty.....	6
Emission Control System Components.....	6
Warranty Policy—Australia and New Zealand.....	7
Global Warranty Charts Outboard and Jets.....	11

General Information

Boater's Responsibilities.....	16
Before Operating Your Mercury Jet Drive.....	16
Boat Horsepower Capacity.....	17
High-Speed and High-Performance Boat Operation.....	17
Towing the Watercraft in Water.....	17
Mercury Jet Drive Remote Control.....	18
Lanyard Stop Switch.....	18
Protecting People in the Water.....	20
Exhaust Emissions.....	21
Wave and Wake Jumping.....	23
Stopping the Boat in an Emergency.....	23
Selecting Accessories for Your Mercury Jet Drive.....	24
Safe Boating Suggestions.....	24
Recording Serial Numbers.....	26
Specifications.....	27
Component Identification.....	28

Fuel and Oil

Fuel Requirements.....	29
Fuel Additives.....	29
Avoiding Fuel Flow Restriction.....	29
Low Permeation Fuel Hose Requirement.....	29
Oil Recommendation.....	29
Fuel Recommendations.....	30
Filling Remote Oil Tank.....	31
Filling Engine-Mounted Oil Reservoir Tank.....	31

Features and Controls

Bilge Siphon.....	33
Warning System.....	33

Operation

Before Starting the Engine.....	36
Prestarting Checklist.....	36
Special Operating Instructions.....	37
Engine Break-In Procedure.....	39
Starting the Engine.....	39
Shifting.....	41
Stopping the Engine.....	42

Maintenance

Mercury Jet Drive Care.....	43
Replacement Parts for Your Power Package.....	43
EPA Emissions Regulations.....	43
Inspection and Maintenance Schedule.....	44
Clearing A Clogged Water Intake.....	46
Fuel System.....	47
Fuses	49
Corrosion Control Anodes.....	51
Battery Inspection	51
Spark Plug Inspection and Replacement.....	52
Flywheel Cover Removal and Installation.....	54
Alternator Belt Inspection.....	56
Compressor Air Intake Filter.....	56
Belt Tensioner Idler Pulley Lubrication.....	57
Flushing the Cooling System.....	57
Drive Housing Lubricant.....	59
Stator Assembly Lubricant.....	60
Bilge Siphon Inspection.....	62
Submerged Power Package.....	63

Storage

Storage Preparation.....	64
Protecting Internal Engine Components.....	65

Troubleshooting

Starter Motor Will Not Crank the Engine.....	66
Engine Will Not Start.....	66
Engine Runs Erratically.....	66
Performance Loss at Normal RPM.....	67
Performance Loss at Wide-Open Throttle.....	67
Battery Will Not Hold Charge.....	67

Owner Service Assistance

Local Repair Service.....	68
Service Away from Home.....	68
Stolen Power Package.....	68
Attention Required After Submersion.....	68
Replacement Service Parts.....	68
Parts and Accessories Inquiries.....	68
Resolving a Problem.....	69
Contact Information for Mercury Marine Customer Service.....	69
Ordering Literature.....	70

Maintenance Log

Maintenance Log.....	72
----------------------	----

WARRANTY INFORMATION

Warranty Registration United States and Canada

To be eligible for warranty coverage, the product must be registered with Mercury Marine.

At the time of sale, the selling dealer should complete the warranty registration and immediately submit it to Mercury Marine via MercNET, e-mail, or mail. Upon receipt of this warranty registration, Mercury Marine will record the registration.

A copy of the warranty registration should be provided to you by your selling dealer.

NOTE: *Registration lists must be maintained by Mercury Marine and any dealer of Mercury Marine products sold in the United States, should a safety recall notification under the Federal Safety Act be required.*

You may change your registered address at any time, including at time of warranty claim, by calling Mercury Marine or sending a letter or fax with your name, old address, new address, and engine serial number to Mercury Marine's warranty registration department. Your dealer can also process this change of information.

Mercury Marine
Attn: Warranty Registration Department
W6250 Pioneer Road
P.O. Box 1939
Fond du Lac, WI 54936-1939
920-929-5054
Fax +1 920 907 6663

OUTSIDE UNITED STATES AND CANADA

For products purchased outside the United States and Canada, contact the distributor in your country, or the Marine Power Service Center closest to you.

Transfer of Warranty United States and Canada

The limited warranty is transferable to a subsequent purchaser, but only for the remainder of the unused portion of the limited warranty. This will not apply to products used for commercial applications.

To transfer the warranty to the subsequent owner, send or fax a copy of the bill of sale or purchase agreement, new owner's name, address, and engine serial number to Mercury Marine's warranty registration department. In the United States and Canada, mail to:

Mercury Marine
Attn: Warranty Registration Department
W6250 Pioneer Road
P.O. Box 1939
Fond du Lac, WI 54936-1939
920-929-5054
Fax +1 920 907 6663

WARRANTY INFORMATION

Upon processing the transfer of warranty, Mercury Marine will record the new owner's information.

There is no charge for this service.

OUTSIDE THE UNITED STATES AND CANADA

For products purchased outside the United States and Canada, contact the distributor in your country, or the Marine Power Service Center closest to you.

Transfer of Mercury Product Protection (Extended Service Coverage) Plan United States and Canada

The remaining coverage period of the Product Protection Plan is transferable to the subsequent purchaser of the engine within thirty (30) days from the date of sale. Contracts not transferred within thirty (30) days of the subsequent purchase will no longer be valid and the product will no longer be eligible for coverage under the terms of the contract.

To transfer the plan to the subsequent owner, contact Mercury Product Protection or an authorized dealer to receive a Request for Transfer form. Submit to Mercury Product Protection a receipt/bill of sale, a completed Request of Transfer form, and a check payable to Mercury Marine in the amount of \$50.00 (per engine) to cover the transfer fee.

Plan coverage is not transferable from one product to another product or for noneligible applications.

The certified preowned engine plans are not transferable.

For help or assistance, contact Mercury Product Protection Department at 1-888-427-5373 from 7:30 a.m. to 4:30 p.m. CST, Monday–Friday or e-mail mpp_support@mercmarine.com.

3 Year Limited Warranty Against Corrosion

WHAT IS COVERED: Mercury Marine warrants that each new Mercury, Mariner, Mercury Racing, Sport-Jet, M² Jet Drive, Tracker by Mercury Marine Outboard, Mercury MerCruiser Inboard or Sterndrive Engine (Product) will not be rendered inoperative as a direct result of corrosion for the period of time described below.

DURATION OF COVERAGE: This limited corrosion warranty provides coverage for three (3) years from either the date the product is first sold, or the date on which the product is first put into service, whichever occurs first. The repair or replacement of parts, or the performance of service under this warranty, does not extend the life of this warranty beyond its original expiration date. Unexpired warranty coverage can be transferred to subsequent (noncommercial use) purchaser upon proper reregistration of the product.

WARRANTY INFORMATION

CONDITIONS THAT MUST BE MET IN ORDER TO OBTAIN WARRANTY

COVERAGE: Warranty coverage is available only to retail customers that purchase from a Dealer authorized by Mercury Marine to distribute the product in the country in which the sale occurred, and then only after the Mercury Marine specified pre-delivery inspection process is completed and documented. Warranty coverage becomes available upon proper registration of the product by the authorized dealer. Corrosion prevention devices specified in the Operation and Maintenance Manual must be in use on the boat, and routine maintenance outlined in the Operation and Maintenance Manual must be timely performed (including, without limitation, the replacement of sacrificial anodes, use of specified lubricants, and touch-up of nicks and scratches) in order to maintain warranty coverage. Mercury Marine reserves the right to make warranty coverage contingent upon proof of proper maintenance.

WHAT MERCURY WILL DO: Mercury's sole and exclusive obligation under this warranty is limited to, at our option, repairing a corroded part, replacing such part or parts with new or Mercury Marine certified remanufactured parts, or refunding the purchase price of the Mercury product. Mercury reserves the right to improve or modify products from time to time without assuming an obligation to modify products previously manufactured.

HOW TO OBTAIN WARRANTY COVERAGE: The customer must provide Mercury with a reasonable opportunity to repair, and reasonable access to the product for warranty service. Warranty claims shall be made by delivering the product for inspection to a Mercury dealer authorized to service the product. If purchaser cannot deliver the product to such a dealer, written notice must be given to Mercury. We will then arrange for the inspection and any covered repair. Purchaser, in that case, shall pay for all related transportation charges and/or travel time. If the service provided is not covered by this warranty, purchaser shall pay for all related labor and material, and any other expenses associated with that service. Purchaser shall not, unless requested by Mercury, ship the product or parts of the product directly to Mercury. Proof of registered ownership must be presented to the dealer at the time warranty service is requested in order to obtain coverage.

WHAT IS NOT COVERED: This limited warranty does not cover electrical system corrosion; corrosion resulting from damage, corrosion which causes purely cosmetic damage, abuse, or improper service; corrosion to accessories, instruments, steering systems; corrosion to factory installed jet drive unit; damage due to marine growth; product sold with less than a one year limited Product warranty; replacement parts (parts purchased by customer); products used in a commercial application. Commercial use is defined as any work or employment related use of the product, or any use of the product which generates income, for any part of the warranty period, even if the product is only occasionally used for such purposes.

WARRANTY INFORMATION

Corrosion damage caused by stray electrical currents (onshore power connections, nearby boats, submerged metal) is not covered by this corrosion warranty and should be protected against by the use of a corrosion protection system, such as the Mercury Precision Parts or Quicksilver MerCathode system and/or Galvanic Isolator. Corrosion damage caused by improper application of copper base antifouling paints is also not covered by this limited warranty. If antifouling protection is required, Tri-Butyl-Tin-Adipate (TBTA) base antifouling paints are recommended on Outboard and MerCruiser boating applications. In areas where TBTA base paints are prohibited by law, copper base paints can be used on the hull and transom. Do not apply paint to the outboard or MerCruiser product. In addition, care must be taken to avoid an electrical interconnection between the warranted product and the paint. For MerCruiser product, an unpainted gap of at least 38 mm (1.5 in.) should be left around the transom assembly. Refer to the Operation and Maintenance Manual for additional details.

For additional information regarding events and circumstances covered by this warranty, and those that are not, see the Warranty Coverage section of the Operation and Maintenance Manual, incorporated by reference into this warranty.

DISCLAIMERS AND LIMITATIONS:

THE IMPLIED WARRANTIES OF MERCHANTABILITY AND FITNESS FOR A PARTICULAR PURPOSE ARE EXPRESSLY DISCLAIMED. TO THE EXTENT THAT THEY CANNOT BE DISCLAIMED, THE IMPLIED WARRANTIES ARE LIMITED IN DURATION TO THE LIFE OF THE EXPRESS WARRANTY. INCIDENTAL AND CONSEQUENTIAL DAMAGES ARE EXCLUDED FROM COVERAGE UNDER THIS WARRANTY. SOME STATES/COUNTRIES DO NOT ALLOW FOR THE DISCLAIMERS, LIMITATIONS AND EXCLUSIONS IDENTIFIED ABOVE, AS A RESULT, THEY MAY NOT APPLY TO YOU. THIS WARRANTY GIVES YOU SPECIFIC LEGAL RIGHTS, AND YOU MAY ALSO HAVE OTHER LEGAL RIGHTS WHICH VARY FROM STATE TO STATE AND COUNTRY TO COUNTRY.

Warranty Coverage and Exclusions

The purpose of this section is to help eliminate some of the more common misunderstandings regarding warranty coverage. The following information explains some of the types of services that are not covered by warranty. The provisions set forth following have been incorporated by reference into the Three Year Limited Warranty Against Corrosion Failure, the International Limited Outboard Warranty, and the United States and Canada Limited Outboard Warranty.

Keep in mind that warranty covers repairs that are needed within the warranty period because of defects in material and workmanship. Installation errors, accidents, normal wear, and a variety of other causes that affect the product are not covered.

WARRANTY INFORMATION

Warranty is limited to defects in material or workmanship, but only when the consumer sale is made in the country to which distribution is authorized by us. Should you have any questions concerning warranty coverage, contact your authorized dealer. They will be pleased to answer any questions that you may have.

GENERAL EXCLUSIONS FROM WARRANTY

1. Minor adjustments and tune-ups made in connection with normal services, including checking lubrication and checking, cleaning, or adjusting spark plugs, ignition components, carburetor settings, filters, belts, and controls.
2. Factory installed jet drive units - Specific parts excluded from the warranty are: the jet drive impeller and jet drive liner damaged by impact or wear, and water damaged driveshaft bearings as a result of improper maintenance.
3. Damage caused by neglect, lack of maintenance, accident, abnormal operation, or improper installation or service.
4. Haul-out, launch, towing charges, removal and/or replacement of boat partitions or material because of boat design for necessary access to the product, all related transportation charges and/or travel time, etc. Reasonable access must be provided to the product for warranty service. Customer must deliver product to an authorized dealer.
5. Additional service work requested by customer other than that necessary to satisfy the warranty obligation.
6. Labor performed by other than an authorized dealer may be covered only under the following circumstances: when performed on emergency basis (providing there are no authorized dealers in the area who can perform the work required or have no facilities to haul-out, etc., and prior factory approval has been given to have the work performed at this facility).
7. All incidental and/or consequential damages (storage charges, telephone or rental charges of any type, inconvenience or loss of time or income) are the owner's responsibility.
8. Use of other than Mercury Precision or Quicksilver parts when making warranty repairs.
9. Oils, lubricants, or fluids changed as a matter of normal maintenance is customer's responsibility unless loss or contamination of same is caused by product failure that would be eligible for warranty consideration.
10. Participating in or preparing for racing or other competitive activity or operating with a racing type lower unit.
11. Engine noise does not necessarily indicate a serious engine problem. If diagnosis indicates a serious internal engine condition that could result in a failure, the condition responsible for the noise should be corrected under the warranty.
12. Product damage caused by striking a submerged object is considered a marine hazard.

WARRANTY INFORMATION

13. Water entering the engine through the fuel intake, air intake, or exhaust system or submersion.
14. Failure of any parts caused by lack of cooling water resulting from starting the motor out of water, foreign material blocking the inlet holes, or the motor being mounted too high.
15. Use of fuels and lubricants that are not suitable for use with or on the product. Refer to the **Maintenance** section.
16. Our limited warranty does not apply to any damage to our products caused by the installation or use of parts and accessories that are not manufactured or sold by us. Failures that are not related to the use of those parts or accessories are covered under warranty if they otherwise meet the terms of the limited warranty for that product.

U.S. EPA Emissions Limited Warranty

Consistent with the obligations created by 40 CFR Part 1045, Subpart B, Mercury Marine provides an emission warranty of three years or 480 hours of engine use whichever occurs first to the retail purchaser, that the engine is designed, built, and equipped so as to conform at the time of sale with applicable regulations under section 213 of the Clean Air Act, and that the engine is free from defects in materials and workmanship that cause the engine to fail to conform with applicable regulations.

Emission Control System Components

The emission-related warranty covers all components whose failure would increase an engine's emission of any regulated component including the following list of components:

1. Fuel metering system
 - a. Carburetor and internal parts (or fuel pressure regulator or fuel injection system)
 - b. Air/fuel ratio feedback and control system
 - c. Cold start enrichment system
 - d. Intake valves
2. Air induction system
 - a. Controlled hot air intake system
 - b. Intake manifold
 - c. Air filter
 - d. Turbocharger systems
 - e. Heat riser valve and assembly
3. Ignition system
 - a. Spark plugs
 - b. Magneto or electronic ignition system
 - c. Spark control system

WARRANTY INFORMATION

- d. Ignition coil or control module
- e. Ignition wires
- 4. Lubrication system
 - a. Oil pump and internal parts
 - b. Oil injectors
 - c. Oil meter
- 5. Positive crankcase ventilation (PCV) system
 - a. PCV valve
 - b. Oil filler cap
- 6. Exhaust system
 - a. Exhaust manifold
 - b. Exhaust elbow
 - c. Intermediate exhaust elbow
 - d. Lower exhaust pipe
 - e. Tailpipe
- 7. Catalysts or thermal reactor system
 - a. Catalytic converter
 - b. Thermal reactor
 - c. Exhaust manifold
 - d. Exhaust valves
- 8. Miscellaneous items used in above systems
 - a. Hoses, clamps, fittings, tubing, sealing gaskets or devices, and mounting hardware
 - b. Pulleys, belts, and idlers
 - c. Vacuum, temperature, check and time sensitive valves and switches
 - d. Electronic controls

NOTE: *The emission-related warranty does not cover components whose failure would not increase an engine's emissions on any regulated pollutant.*

Warranty Policy—Australia and New Zealand

MERCURY/MARINER OUTBOARD LIMITED WARRANTY—AUSTRALIA AND NEW ZEALAND POLICY

This limited warranty is given by Marine Power International Pty Ltd ACN 003 100 007 of 41–71 Bessemer Drive, Dandenong South, Victoria 3175 Australia (telephone (61) (3) 9791 5822) e-mail: merc_info@mercmarine.com.

WARRANTY INFORMATION

What is Covered

Mercury Marine warrants its new products to be free of defects in material and workmanship during the period described following. The benefits to the consumer given by the warranty are in addition to other rights and remedies of the consumer under a law in relation to the goods or services to which the warranty relates.

Guarantees Under Australian Consumer Law

Our goods come with guarantees that cannot be excluded under the Australian Consumer Law. You are entitled to a replacement or refund for a major failure and compensation for any other reasonably foreseeable loss or damage. You are also entitled to have the goods repaired or replaced if the goods fail to be of acceptable quality and the failure does not amount to a major failure.

Warranty Period for Recreational Use

This Limited Warranty provides coverage for three (3) years from the date the product is first sold to a recreational use retail purchaser, or the date on which the product is first put into service, whichever occurs first. Unexpired warranty coverage can be transferred to a subsequent recreational use customer upon proper registration of the product.

Warranty Period for Commercial Use

Commercial users of these products receive warranty coverage under this Limited Warranty of one (1) year from the date of first retail sale, or one (1) year from the date on which the product was first put into service, whichever occurs first. Commercial use is defined as any work or employment related use of the product, or any use of the product that generates income, for any part of the warranty period, even if the product is only occasionally used for such purposes. Unexpired warranty coverage cannot be transferred either to or from a commercial use customer.

Conditions That Must Be Met to Obtain Warranty Coverage

Warranty coverage under this Limited Warranty is available only to retail customers that purchase from a dealer authorized by Mercury Marine to distribute the product in the country in which the sale occurred, and then only after the Mercury Marine specified pre-delivery inspection process is completed and documented. Warranty coverage becomes available upon proper registration of the product by the authorized dealer. Inaccurate warranty registration information regarding recreational use, or subsequent change of use from recreational to commercial (unless properly registered) may void the warranty at the sole discretion of Mercury Marine. Routine maintenance outlined in this Operation and Maintenance Manual must be timely performed in order to maintain warranty coverage. Mercury Marine reserves the right to make warranty coverage contingent upon proof of proper maintenance.

WARRANTY INFORMATION

What Mercury Will Do

Mercury Marine's sole and exclusive obligation under this Limited Warranty is limited to, at our option, repairing a defective part, replacing such part or parts with new or Mercury Marine certified remanufactured parts, or refunding the purchase price of the Mercury Marine product. Mercury Marine reserves the right to improve or modify products from time to time without assuming an obligation to modify products previously manufactured.

How to Obtain Warranty Coverage Under This Limited Warranty

The customer must provide Mercury Marine with a reasonable opportunity to repair and reasonable access to the product for warranty service. Warranty claims shall be made by delivering the product for inspection to a Mercury Marine dealer authorized to service the product. A list of dealers and their contact details is available at www.mercurymarine.com.au. If the purchaser cannot deliver the product to such a dealer, written notice must be given to Mercury Marine at the address shown above. Mercury Marine will then arrange for the inspection and any covered repair. This Limited Warranty will not cover the purchaser for all related transportation charges and travel time. If the service provided is not covered by this limited warranty, the purchaser shall pay for all related labor and material and any other expenses associated with that service, provided that a consumer will not be obligated to pay where the service has been carried out to remedy a failure of an acceptable quality guarantee that is binding on Mercury Marine under the Australian Consumer Law. The purchaser shall not, unless requested by Mercury Marine, ship the product or parts of the product directly to Mercury Marine. Proof of registered ownership must be presented to the dealer at the time warranty service is requested in order to obtain coverage under this Limited Warranty.

What is Not Covered

This limited warranty does not cover routine maintenance items, tune-ups, adjustments, normal wear and tear, damage caused by abuse, abnormal use, use of a propeller or gear ratio that does not allow the engine to run in its recommended wide-open throttle RPM range, operation of the product in a manner inconsistent with the recommended operation/duty cycle, neglect, accident, submersion, improper installation (proper installation specifications and techniques are set forth in the installation instructions for the product), improper service, use of an accessory or part not manufactured or sold by us, jet pump impellers and liners, operation with fuels, oils or lubricants that are not suitable for use with the product, alteration or removal of parts, water entering the engine through the fuel intake, air intake or exhaust system, or damage to the product from insufficient cooling water caused by blockage of the cooling system by a foreign body, running the engine out of water, mounting the engine too high on the transom, or running the boat with the engine trimmed out too far. Use of the product for racing or other competitive activity, or operating with a racing type lower unit, at any point, even by a prior owner of the product, voids the warranty.

WARRANTY INFORMATION

Expenses related to haul-out, launch, towing, storage, telephone, rental, inconvenience, slip fees, insurance coverage, loan payments, loss of time, loss of income, or any other type of incidental or consequential damages are not covered by this Limited Warranty. Also, expenses associated with work done to gain access to the product, such as the removal or replacement of boat partitions or material designed into the boat, are not covered by this warranty.

No individual or entity, including Mercury Marine authorized dealers, has been given authority by Mercury Marine to make any affirmation, representation or warranty regarding the product, other than those contained in this limited warranty, and if made, shall not be enforceable against Mercury Marine. For additional information regarding events and circumstances covered by this warranty, and those that are not, refer to the **Warranty Coverage and Exclusions** section of this manual, incorporated by reference into this warranty.

Expense of Claiming This Limited Warranty

This Limited Warranty does not cover any expenses you may incur claiming the warranty.

DISCLAIMERS AND LIMITATIONS:

EXCEPT FOR APPLICABLE GUARANTEES AND OTHER RIGHTS AND REMEDIES THAT A CONSUMER MAY HAVE UNDER THE AUSTRALIAN CONSUMER LAW OR OTHER LAW IN RELATION TO WHICH THE PRODUCTS RELATE, THE IMPLIED WARRANTIES OF MERCHANTABILITY AND FITNESS FOR A PARTICULAR PURPOSE ARE EXPRESSLY DISCLAIMED. TO THE EXTENT THAT THEY CANNOT BE DISCLAIMED, THE IMPLIED WARRANTIES ARE LIMITED IN DURATION TO THE LIFE OF THE EXPRESS WARRANTY. INCIDENTAL AND CONSEQUENTIAL DAMAGES ARE EXCLUDED FROM COVERAGE UNDER THIS LIMITED WARRANTY.

TRANSFER OF WARRANTY—AUSTRALIA AND NEW ZEALAND POLICY

The limited warranty is transferable to a subsequent purchaser, but only for the remainder of the unused portion of the limited warranty. This will not apply to products used for commercial applications.

To transfer the warranty to the subsequent owner, send or fax a copy of the Bill of Sale or Purchase Agreement, new owner's name, address, and hull identification number (HIN) to Mercury Marine's Warranty Registration Department. In Australia and New Zealand, mail to:

WARRANTY INFORMATION

Mercury Marine
Attn: Warranty Registration Department
Brunswick Asia Pacific Group
Private Bag 1420
Dandenong South, Victoria 3164
Australia

Upon processing the transfer of warranty, Mercury Marine will send registration verification to the new owner of the product by mail. There is no charge for this service.

You may change your address at any time, including at the time of the warranty claim, by calling Mercury Marine or sending a letter or fax with your name, old address, new address, and hull identification number (HIN) to Mercury Marine's Warranty Registration Department.

Global Warranty Charts Outboard and Jets

UNITED STATES WARRANTY CHARTS—OUTBOARD AND JET

Product	Standard Limited Warranty	Standard Limited Corrosion Warranty
FourStroke (2.5 - 300 hp including Verado, Pro FourStroke and jet outboards)	3 years	3 years
OptiMax (75 - 250 hp including Pro XS and jet outboards)	3 years	3 years
OptiMax jet drive (200 and 250 hp)	1 year	3 years

Racing Product (Recreation use only)	Standard Limited Warranty	Standard Limited Corrosion Warranty
OptiMax (250 XS)	2 years	3 years
OptiMax (225 Sport XS)	2 years	3 years
OptiMax (300 XS)	2 years	3 years
Verado (350 SCi)	2 years	3 years

Outside the United States

For product purchased outside the United States, contact the distributor in your country, or the authorized Marine Power Service Center closest to you.

WARRANTY INFORMATION

CANADA WARRANTY CHARTS—OUTBOARD AND JET

Product	Standard Limited Warranty	Standard Limited Corrosion Warranty
2-Stroke carbureted (50 - 90 hp)	1 year	3 years
2-Stroke EFI (150 hp)	2 years	3 years
2-Stroke carbureted (V6)	2 years	3 years
FourStroke (2.5 - 300 hp including Verado, Pro FourStroke and jet outboards)	3 years	3 years
OptiMax (75 - 250 hp including Pro XS and jet outboards)	3 years	3 years
OptiMax jet drive (200 and 250 hp)	1 year	3 years

Racing Product (Recreation use only)	Standard Limited Warranty	Standard Limited Corrosion Warranty
OptiMax (250 XS)	2 years	3 years
OptiMax (225 Sport XS)	2 years	3 years
OptiMax (300 XS)	2 years	3 years
Verado (350 SCi)	2 years	3 years

Outside of Canada

For product purchased outside of Canada, contact the distributor in your country, or the authorized Marine Power Service Center or dealer closest to you.

AUSTRALIA AND NEW ZEALAND WARRANTY CHARTS—OUTBOARD AND JET

Products	Standard Limited Warranty	Standard Limited Corrosion Warranty	Light Commercial
All outboard	3 years	3 years	Contact the Marine Power Service Center closest to you

Outside of Australia and New Zealand

For product purchased outside of Australia and New Zealand, contact the distributor in your country, or the Marine Power Service Center closest to you.

WARRANTY INFORMATION

SOUTH PACIFIC WARRANTY CHART–OUTBOARD AND JET

Products	Standard Limited Warranty	Standard Limited Corrosion Warranty	Light Commercial
All outboard	2 years	3 years	Contact the Marine Power Service Center closest to you

Outside of South Pacific

For product purchased outside of the South Pacific region, contact the distributor in your country, or the Marine Power Service Center closest to you.

ASIA WARRANTY CHARTS–OUTBOARD AND JET

Product (Recreational only)	Standard Limited Warranty	Standard Limited Corrosion Warranty	Commercial Application
2-Stroke	1 year	3 years	Contact the Marine Power Service Center closest to you
FourStroke	1 year	3 years	
OptiMax	1 year	3 years	
Verado	1 year	3 years	

Racing Product (Recreational only)	Standard Limited Warranty	Standard Limited Corrosion Warranty	Commercial Application
Verado 350 SCi	1 year	3 years	None

Outside of Asia

For product purchased outside of the Asian region, contact the distributor in your country, or the Marine Power Service Center closest to you.

WARRANTY INFORMATION

EUROPE AND THE CONFEDERATION OF INDEPENDENT STATES (CIS) WARRANTY CHARTS—OUTBOARD AND JET

Product (Recreational only)	Standard Limited Warranty	Standard Limited Corrosion Warranty	Commercial Application
2-Stroke	2 years	3 years	Contact the Marine Power Service Center closest to you
FourStroke	2 years	3 years	
OptiMax (including Pro XS)	3 years	3 years	
Verado (including Pro)	3 years	3 years	

Racing Product (Recreational only)	Standard Limited Warranty	Standard Limited Corrosion Warranty	Commercial Application
Verado 350 SCi	2 years	3 years	Contact the Marine Power Service Center closest to you

Outside Europe and CIS

For products purchased outside of Europe and CIS regions, contact the distributor in your country, or the Marine Power Service Center closest to you.

MIDDLE-EAST AND AFRICA (EXCLUDING SOUTH AFRICA) WARRANTY CHARTS—OUTBOARD AND JET

Product (Recreational only)	Standard Limited Warranty	Standard Limited Corrosion Warranty	Commercial Application
2-Stroke	1 year	3 years	Contact the Marine Power Service Center closest to you
FourStroke	2 years	3 years	
OptiMax (including Pro XS)	3 years	3 years	
Verado (including Pro)	3 years	3 years	

WARRANTY INFORMATION

Racing Product (Recreational only)	Standard Limited Warranty	Standard Limited Corrosion Warranty
Verado 350 SCi	2 years	3 years

Outside Middle-East and Africa

For products purchased outside of the Middle-East and Africa regions, contact the distributor in your country, or the Marine Power Service Center closest to you.

SOUTH AFRICA WARRANTY CHARTS—OUTBOARD AND JET

Product (Recreational only)	Standard Limited Warranty	Standard Limited Corrosion Warranty	Commercial Application
2-Stroke	2 years	3 years	Contact the Marine Power Service Center closest to you
FourStroke	2 years	3 years	
OptiMax (including Pro XS)	3 years	3 years	
Verado (including Pro)	3 years	3 years	

Racing Product (Recreational only)	Standard Limited Warranty	Standard Limited Corrosion Warranty
Verado 350 SCi	2 years	3 years

Outside South Africa

For products purchased outside of the South Africa region, contact the distributor in your country, or the Marine Power Service Center closest to you.

GENERAL INFORMATION

Boater's Responsibilities

The operator (driver) is responsible for the correct and safe operation of the boat and safety of its occupants and general public. It is strongly recommended that each operator (driver) read and understand this entire manual before operating the power package.

Be sure at least one additional person on board is instructed in the basics of starting and operating the Mercury Jet Drive, and boat handling in case the driver is unable to operate the boat.

Before Operating Your Mercury Jet Drive

Read this manual carefully. Safety and operating information that is practiced along with using good common sense can help prevent personal injury and product damage. If you have any questions, contact your dealer.

This manual as well as safety labels posted on the Mercury Jet Drive use safety alerts to draw your attention to special safety instructions that must be followed.

▲ DANGER

Indicates a hazardous situation which, if not avoided, will result in death or serious injury.

▲ WARNING

Indicates a hazardous situation which, if not avoided, could result in death or serious injury.

▲ CAUTION

Indicates a hazardous situation which, if not avoided, could result in minor or moderate injury.

NOTICE

Indicates a situation which, if not avoided, could result in engine or major component failure.

IMPORTANT: Indicates information or instructions that are necessary for proper operation and/or maintenance.

Read this manual carefully. Learn the difference in handling characteristics between a Mercury Jet Drive boat and a propeller driven boat including:

- *Steering at low power/throttle* - unlike propeller driven boats, the Mercury Jet Drive boat tends to lose steering control as less water is drawn in and expelled. Increase power/throttle slightly to regain steering.
- *Maneuverability* - the Mercury Jet Drive is highly maneuverable at higher speeds; more so, than propeller driven boats. Use caution when turning to prevent spinouts.

GENERAL INFORMATION

- *Steering in reverse* - unlike propeller driven boats, turning the steering wheel turns the bow of the boat in the *same direction*.

If you have any questions, contact your dealer.

Safety and operating information that is practiced along with using good common sense can help prevent personal injury and product damage.

Boat Horsepower Capacity

▲ WARNING

Exceeding the boat's maximum horsepower rating can cause serious injury or death. Overpowering the boat can affect boat control and flotation characteristics or break the transom. Do not install an engine that exceeds the boat's maximum power rating.

Do not overpower or overload your boat. Most boats will carry a required capacity plate indicating the maximum acceptable power and load as determined by the manufacturer following certain federal guidelines. If in doubt, contact your dealer or the boat manufacturer.

U.S. COAST GUARD CAPACITY	
MAXIMUM HORSEPOWER	XXX
MAXIMUM PERSON CAPACITY (POUNDS)	XXX
MAXIMUM WEIGHT CAPACITY	XXX

26777

High-Speed and High-Performance Boat Operation

If your Mercury Jet Drive is to be used in a high-speed or high-performance boat with which you are unfamiliar, we recommend that you never operate it at its high speed capability without first requesting an initial orientation and familiarization demonstration ride with your dealer or an operator experienced with your Mercury Jet Drive. For additional information, obtain a copy of our **Hi-Performance Boat Operation** booklet from your dealer, distributor, or Mercury Marine.

Towing the Watercraft in Water

If towing a stranded Mercury Jet Drive powered watercraft in water, the towing speed must be slow. Keep the towing speed at or around idle speed.

Keeping the towing speed slow will prevent water from being forced up through the exhaust system and into the engine. Water entering the engine can cause damage to internal engine parts.

GENERAL INFORMATION

Mercury Jet Drive Remote Control

The remote control connected to your Mercury Jet Drive must be equipped with a start-in-gear protection device. This prevents the engine from starting when the Mercury Jet Drive is in forward or reverse.

⚠ WARNING

Starting the engine with the drive in gear can cause serious injury or death. Never operate a boat that does not have a neutral-safety-protection device.

Lanyard Stop Switch

The purpose of a lanyard stop switch is to turn off the engine when the operator moves far enough away from the operator's position to activate the switch (as in accidental ejection from the operator's position). Tiller handle outboards and some remote control units are equipped with a lanyard stop switch. A lanyard stop switch can be installed as an accessory - generally on the dashboard or side adjacent to the operator's position.

A decal near the lanyard stop switch is a visual reminder for the operator to attach the lanyard to their personal flotation device (PFD) or wrist.

The lanyard cord is usually 122–152 cm (48–60 in.) in length when stretched out. It has an element on one end made to be inserted into the switch and a clip on the other end for attaching to the operator's PFD or wrist. The lanyard is coiled to make its at-rest condition as short as possible to minimize the likelihood of entanglement with nearby objects. Its stretched-out length is made to minimize the likelihood of accidental activation should the operator choose to move around in an area close to the normal operator's position. If it is desired to have a shorter lanyard, wrap the lanyard around the operator's wrist or leg, or tie a knot in the lanyard.

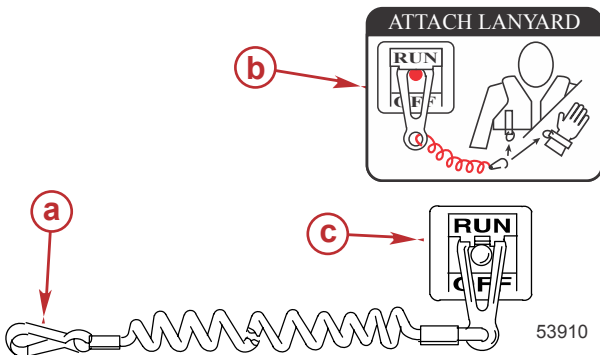

- a** - Lanyard cord clip
- b** - Lanyard decal
- c** - Lanyard stop switch

GENERAL INFORMATION

Read the following safety information before proceeding.

Important Safety Information: The purpose of a lanyard stop switch is to stop the engine when the operator moves far enough away from the operator's position to activate the switch. This would occur if the operator accidentally falls overboard or otherwise moves away from the operator's position.

Falling overboard and accidental ejections are more likely to occur in certain types of boats, such as low sided inflatables, bass boats, high performance boats, and light, sensitive handling fishing boats operated by a hand tiller. Falling overboard and accidental ejections are also likely to occur as a result of poor operating practices, such as sitting on the back of the seat or gunwale at planing speeds, standing at planing speeds, sitting on elevated fishing boat decks, operating at planing speeds in shallow waters or where there are many obstacles, releasing your grip on a steering wheel or tiller handle that is pulling in one direction, drinking alcohol or consuming drugs, or performing high speed boat maneuvers.

While activation of the lanyard stop switch will stop the engine immediately, a boat will continue to coast for some distance, depending upon the velocity and degree of any turn at shutdown. However, the boat will not complete a full circle. While the boat is coasting, it can cause injury to anyone in the boat's path as seriously as the boat would when under power.

Always instruct other occupants on proper starting and operating procedures should they be required to operate the engine in an emergency (if the operator is accidentally ejected).

WARNING

Avoid serious injury or death resulting from being struck by an uncontrolled boat. Failure to use the lanyard safety device substantially increases the risk of being struck by an uncontrolled boat should you, as operator, be ejected. As operator, always use the lanyard stop switch, which will automatically disable the engines in the case of ejection or being thrown from the operator position.

WARNING

Avoid serious injury or death from sudden deceleration forces resulting from accidental or unintended switch activation. The lanyard switch is designed to quickly stop the boat when activated. Be cautious of accidental lanyard switch activation.

Accidental or unintended activation of the switch during normal operation is a possibility. This could cause any, or all, of the following potentially hazardous situations:

- Occupants thrown forward due to the unexpected loss of forward motion - a particular concern for passengers in the front of the boat who could be ejected over the bow and possibly struck by the gearcase or jet drive.

GENERAL INFORMATION

- Loss of power and directional control in heavy seas, strong current, or high winds.
- Loss of control when docking.

KEEP THE LANYARD STOP SWITCH AND LANYARD CORD IN GOOD OPERATING CONDITION

Before each use, check to ensure that the lanyard stop switch works properly. Start the engine, and then stop it by pulling the lanyard cord. If the engine does not stop, have the switch repaired before operating the boat.

Before each use, inspect the lanyard cord to ensure it is in good working condition and that there are no breaks, cuts, or wear to the cord. Check that the clips on the ends of the cord are in good condition. Replace any damaged or worn lanyard cords.

Protecting People in the Water



21604

WHILE YOU ARE CRUISING

A person standing or floating in the water cannot take quick action to avoid a boat heading in his or her direction even at slow speed.

Slow down and exercise extreme caution any time you are boating in an area where people might be in the water.

Avoid shallow water or where any loose material such as sand, shells, seaweed, grass, tree branches, etc. can be sucked in and expelled from the pump as a high speed projectile.

WHILE THE BOAT IS STATIONARY

Stop the Mercury Jet Drive engine immediately whenever anyone in the water is near your boat. The Mercury Jet Drive is always drawing water through the water intake grate when the engine is running. Stay away from the water intake located under the stern (back) of the boat and never insert an object into the water intake or water outlet nozzle while the engine is running.

▲ WARNING

Avoid injury resulting from contacting the rotating impeller or having hair, clothing, or loose objects drawn into the water intake and wrapping around the impeller shaft. Stay away from the water intake and never insert an object into the water intake or water outlet nozzle when the engine is running.

GENERAL INFORMATION

Exhaust Emissions

BE ALERT TO CARBON MONOXIDE POISONING

Carbon monoxide (CO) is a deadly gas that is present in the exhaust fumes of all internal combustion engines, including the engines that propel boats, and the generators that power boat accessories. By itself, CO is odorless, colorless, and tasteless, but if you can smell or taste engine exhaust, you are inhaling CO.

Early symptoms of carbon monoxide poisoning, which are similar to the symptoms of seasickness and intoxication, include headache, dizziness, drowsiness, and nausea.

▲ WARNING

Inhaling engine exhaust gases can result in carbon monoxide poisoning, which can lead to unconsciousness, brain damage, or death. Avoid exposure to carbon monoxide.

Stay clear from exhaust areas when engine is running. Keep the boat well-ventilated while at rest or underway.

STAY CLEAR OF EXHAUST AREAS

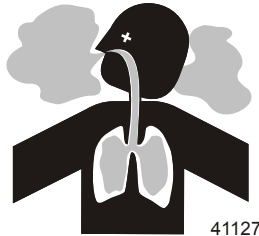

41127

Engine exhaust gases contain harmful carbon monoxide. Avoid areas of concentrated engine exhaust gases. When the engines are running, keep swimmers away from the boat, and do not sit, lie, or stand on swim platforms or boarding ladders. While underway, do not allow passengers to be positioned immediately behind the boat (platform dragging, teak/body surfing). This dangerous practice places a person in an area of high engine exhaust concentration.

GOOD VENTILATION

Ventilate the passenger area. Open side curtains or forward hatches to remove fumes.

GENERAL INFORMATION

Example of desired air flow through the boat:

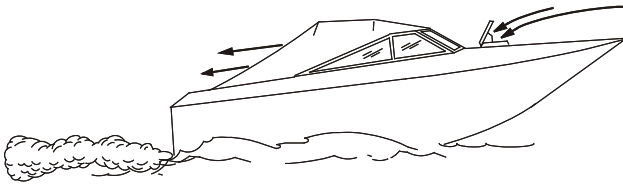

5448

POOR VENTILATION

Under certain running or wind conditions, permanently enclosed cabins, canvas enclosed cabins, or cockpits with insufficient ventilation may draw in carbon monoxide. Install one or more carbon monoxide detectors in your boat.

Although the occurrence is rare, on a calm day, swimmers and passengers in an open area of a stationary boat that contains, or is near, a running engine may be exposed to a hazardous level of carbon monoxide.

1. Examples of poor ventilation while the boat is stationary:

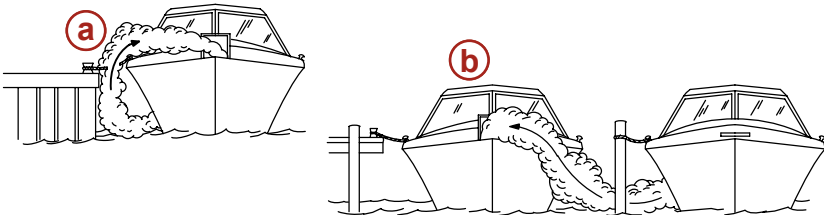

21626

- a** - Running the engine while the boat is moored in a confined space
- b** - Mooring close to another boat that has its engine operating

2. Examples of poor ventilation while the boat is moving:



5449

- a** - Operating the boat with the trim angle of the bow too high
- b** - Operating the boat with no forward hatches open (station wagon effect)

GENERAL INFORMATION

Wave and Wake Jumping

Operating recreational boats over waves and wake is a natural part of boating. However, when this activity is done with sufficient speed to force the boat hull partially or completely out of the water, certain hazards arise, particularly when the boat enters the water.



5450

The primary concern is the boat changing direction while in the midst of the jump. In such case, the landing may cause the boat to veer violently in a new direction. Such a sharp change in direction can cause occupants to be thrown out of their seats, or out of the boat.

⚠ WARNING

Wave or wake jumping can cause serious injury or death from occupants being thrown within or out of the boat. Avoid wave or wake jumping whenever possible.

There is another less common hazardous result from allowing your boat to launch off a wave or wake. If the bow of your boat pitches down far enough while airborne, upon water contact it may penetrate under the water surface and submarine for an instant. This will bring the boat to a nearly instantaneous stop and can send the occupants flying forward. The boat may also steer sharply to one side.

Stopping the Boat in an Emergency

Your jet-powered boat has emergency stopping capability unique to this form of propulsion.

In an emergency, shift the jet drive into reverse and apply the throttle to rapidly slow down the boat and reduce the stopping distance. Keep in mind, however, that such a maneuver may cause occupants in the boat to be thrown forward or even out of the boat.

GENERAL INFORMATION

WARNING

Using the emergency stopping capability of a jet drive unit will slow down the boat in an emergency. However, sudden stopping may cause the occupants of the boat to be thrown forward or out of the boat resulting in serious injury or death. Use caution when performing the emergency stopping procedure, and be sure to practice in a safe area.

Emergency stopping may cause the bow to submerge and take on a large quantity of water, if too much power is applied in reverse. Practice emergency stopping in a safe area, gradually increasing the throttle in reverse until the bow is just above the waterline.

Selecting Accessories for Your Mercury Jet Drive

Genuine Mercury Precision or Quicksilver Accessories have been specifically designed and tested for your Mercury Jet Drive. These accessories are available from Mercury Marine dealers.

IMPORTANT: Check with your dealer before installing accessories. The misuse of approved accessories or the use of nonapproved accessories can damage the product.

Some accessories not manufactured or sold by Mercury Marine are not designed to be safely used with your Mercury Jet Drive. Acquire and read the installation, operation, and maintenance manuals for all your selected accessories.

Safe Boating Suggestions

In order to safely enjoy the waterways, familiarize yourself with local and other governmental boating regulations and restrictions, and consider the following suggestions.

Use flotation devices. Have an approved personal flotation device of suitable size for each person aboard, and have it readily accessible. It is the law.

Do not overload your boat. Most boats are rated and certified for maximum load (weight) capacities. Refer to your boat capacity plate. If in doubt, contact your dealer or the boat's manufacturer.

Perform safety checks and required maintenance. Follow a regular schedule and ensure that all repairs are properly made.

Know and obey all nautical rules and laws of the waterways. Boat operators should complete a boating safety course. Courses are offered in the U.S.A. by the U.S. Coast Guard Auxiliary, the Power Squadron, the Red Cross, and your state or provincial boating law enforcement agency. Inquiries may be made to the Boating Safety Resource Center (www.uscgboating.org/) or the Boat U.S. Foundation (www.boatus.org/courses/).

GENERAL INFORMATION

Make sure everyone in the boat is properly seated. Do not allow anyone to sit or ride on any part of the boat that was not intended for such use. This includes the back of seats, gunwales, transom, bow, decks, raised fishing seats, any rotating fishing seat; or anywhere that an unexpected acceleration, sudden stopping, unexpected loss of boat control, or sudden boat movement could cause a person to be thrown overboard or into the boat.

Never be under the influence of alcohol or drugs while boating. It is the law. Alcohol or drug use impairs your judgment and greatly reduces your ability to react quickly.

Prepare other boat operators. Instruct at least one other person onboard in the basics of starting and operating your Mercury Jet Drive, and boat handling, in case the driver becomes disabled or falls overboard.

Passenger boarding. Stop the engine whenever passengers are boarding, unloading, or are near the back (stern) of the boat. Just shifting the outboard into neutral is not sufficient.

Be alert. The operator of the boat is responsible by law to maintain a proper lookout by sight and hearing. The operator must have an unobstructed view particularly to the front. No passengers, load, or fishing seats should block the operator's view when operating the boat above idle speed.

Never drive your boat directly behind a water-skier in case the skier falls. In five seconds, your boat traveling at 40 km/h (25 mph) will overtake a fallen skier who was 61 m (200 ft) in front of you.

Watch fallen skiers. When using your boat for waterskiing or similar activities, always keep a fallen or down skier on the operator's side of the boat while returning to assist the skier. The operator should always have the down skier in sight and never back up to the skier or anyone in the water.

Report accidents. Boat operators are required by law to file a Boating Accident Report with their state boating law enforcement agency when their boat is involved in certain boating accidents. A boating accident must be reported if 1) there is loss of life or probable loss of life, 2) there is personal injury requiring medical treatment beyond first aid, 3) there is damage to boats or other property where the damage value exceeds \$500.00, or 4) there is complete loss of the boat. Seek further assistance from local law enforcement.

Avoid shallow water conditions. Avoid operating your Mercury Jet Drive in shallow water or where there is a noticeable amount of floating debris or weeds. Never operate your boat in water that is less than 1 m (3 ft) deep, especially when accelerating from idle speeds. Any loose material such as sand, shells, stones, seaweed, grass, etc. can be drawn up by the pump and may cause any of the following problems:

1. Overheated engine
2. Steering loss
3. Objects expelled from the pump at high speeds
4. Pump damage

GENERAL INFORMATION

Recording Serial Numbers

ENGINE AND JET PUMP

It is important to record the engine and jet pump serial numbers for future reference. These serial numbers are different and unique. For convenience, a decal listing both the powerhead and pump serial number is located on the engine.

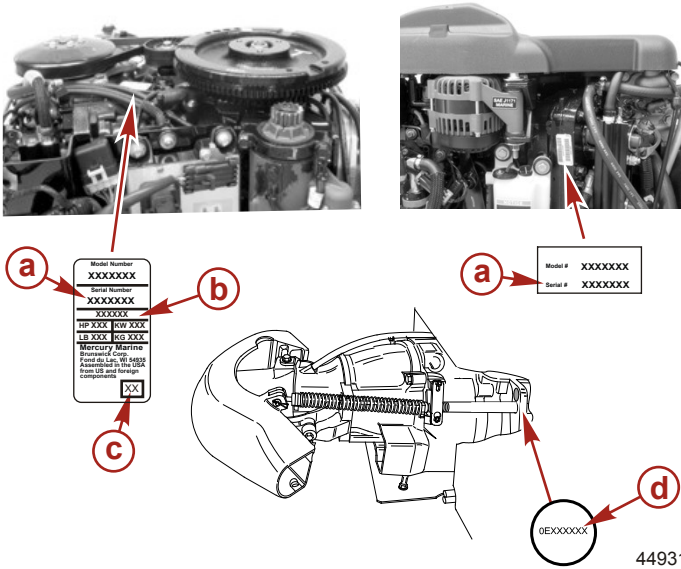

- a** - Engine serial number
- b** - Model designation
- c** - Year of manufacture
- d** - Pump serial number

GENERAL INFORMATION

Specifications

Description	Specifications
Model	200
Horsepower	200
Kilowatts	149.1
Full throttle RPM range	5150–5650
Idle speed RPM range	900–1000
Number of cylinders	6
Piston displacement	2508 cc (153 in ³)
Cylinder bore	88.4 mm (3.500 in.)
Stroke	67.3 mm (2.650 in.)
Spark plug	NGK IZFR6J-11 or NGK IZFR6J
Spark plug gap	1.1 mm (0.043 in.)
Recommended gasoline	Refer to Fuel and Oil
Recommended oil	Refer to Fuel and Oil
Battery rating* (minimum)	1000 marine cranking amps (MCA) or 800 cold cranking amps (CCA)
Charging system output	60 A
Emission control system	Electronic engine control (EC)

*Battery manufacturers may rate and test their batteries to different standards. MCA, CCA, Ah, and reserve capacity (RC) are the ratings recognized by Mercury Marine. Manufacturers that use standards different than these, such as equivalent MCA, do not meet Mercury Marine battery requirements.

GENERAL INFORMATION

Component Identification

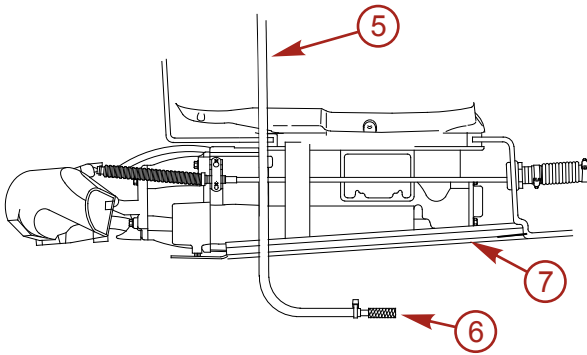
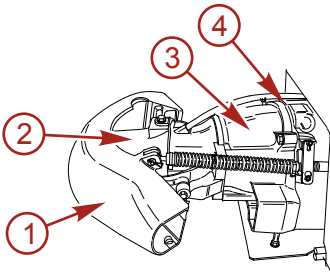

44935

- 1 - Reverse gate
- 2 - Rudder
- 3 - Stator
- 4 - Wear ring
- 5 - Bilge siphon hose - from engine
- 6 - Bilge siphon pickup screen
- 7 - Water intake

FUEL AND OIL

Fuel Requirements

Do not use premixed gas and oil in this engine. The engine automatically receives extra oil during engine break-in. Use a fresh supply of the recommended gasoline during engine break-in and after engine break-in.

Fuel Additives

To minimize carbon deposit buildup in the engine, add Mercury or Quicksilver Quickare Fuel Treatment to the engine's fuel at each tank fill throughout the boating season. Use the additive as directed on the container.

Avoiding Fuel Flow Restriction

IMPORTANT: Adding components to the fuel supply system (filters, valves, fittings, etc.) may restrict the fuel flow. This may cause engine stalling at low speed, and/or a lean fuel condition at high RPM that could cause engine damage.

Low Permeation Fuel Hose Requirement

Required for outboards manufactured for sale, sold, or offered for sale in the United States.

- The Environmental Protection Agency (EPA) requires that any outboard manufactured after January 1, 2009, must use low permeation fuel hose for the primary fuel hose connecting the fuel tank to the outboard.
- Low permeation hose is USCG Type B1-15 or Type A1-15, defined as not exceeding 15/gm²/24 h with CE 10 fuel at 23 °C as specified in SAE J 1527 - marine fuel hose.

Oil Recommendation

Recommended Oil	OptiMax Oil or Premium Plus 2-Cycle TCW 3 Outboard Oil
------------------------	---

Mercury OptiMax/DFI or Quicksilver DFI 2-Cycle Engine Oil is recommended for your engine. If Mercury OptiMax/DFI or Quicksilver DFI 2-Cycle Engine Oil is not available, we recommend using Mercury or Quicksilver TC-W3 Premium Plus 2-Cycle Oil. Severe engine damage may result from use of an inferior oil.

Mercury Racing 2-Stroke Oil is recommended for OptiMax engines that are used in applications of extreme loads associated with commercial, work, or extended periods of high RPM. The added lubrication and protection properties of Mercury Racing 2-Stroke oil maximize engine horsepower while protecting against heat and reduce wear and carbon deposit buildup.

FUEL AND OIL

Fuel Recommendations

IMPORTANT: Use of improper gasoline can damage your engine. Engine damage resulting from the use of improper gasoline is considered misuse of the engine, and damage caused thereby will not be covered under the limited warranty.

FUEL RATINGS

Mercury Marine engines will operate satisfactorily when using a major brand of unleaded gasoline meeting the following specifications:

USA and Canada - having a posted pump octane rating of 87 (R+M)/2 minimum. Premium gasoline (92 [R+M]/2 octane) is also acceptable. Do not use leaded gasoline.

Outside USA and Canada - having a posted pump octane rating of 90 RON minimum. Premium gasoline (98 RON) is also acceptable. Do not use leaded gasoline.

USING REFORMULATED (OXYGENATED) GASOLINES (USA ONLY)

This type of gasoline is required in certain areas of the USA. The two types of oxygenates used in these fuels are alcohol (ethanol) or ether (MTBE or ETBE). If ethanol is the oxygenate that is used in the gasoline in your area, refer to **Gasolines Containing Alcohol**.

These reformulated gasolines are acceptable for use in your Mercury Marine engine.

GASOLINES CONTAINING ALCOHOL

If the gasoline in your area contains either methanol (methyl alcohol) or ethanol (ethyl alcohol), you should be aware of certain adverse effects that can occur. These adverse effects are more severe with methanol. Increasing the percentage of alcohol in the fuel can also worsen these effects.

Some of these adverse effects appear because the alcohol in the gasoline can absorb moisture from the air, resulting in a separation of the alcohol from the gasoline in the fuel tank.

The fuel system components on your Mercury Marine engine will withstand up to 10% alcohol content in the gasoline. We do not know what percentage your boat's fuel system will withstand. Contact your boat manufacturer for specific recommendations on the boat's fuel system components (fuel tanks, fuel lines, and fittings). Be aware that gasolines containing alcohol may cause increased:

- Corrosion of metal parts
- Deterioration of rubber or plastic parts
- Fuel permeation through rubber fuel lines
- Starting and operating difficulties

FUEL AND OIL

⚠ WARNING

Fuel leakage is a fire or explosion hazard, which can cause serious injury or death. Periodically inspect all fuel system components for leaks, softening, hardening, swelling, or corrosion, particularly after storage. Any sign of leakage or deterioration requires replacement before further engine operation.

Because of the possible adverse effects of alcohol in gasoline, use only alcohol-free gasoline where possible. If only fuel containing alcohol is available, or if the presence of alcohol is unknown, increased inspection frequency for leaks and abnormalities is required.

IMPORTANT: When operating a Mercury Marine engine on gasoline containing alcohol, storage of gasoline in the fuel tank for long periods should be avoided. Long periods of storage, common to boats, create unique problems. In cars, alcohol-blend fuels normally are consumed before they can absorb enough moisture to cause trouble, but boats often sit idle long enough for phase separation to take place. In addition, internal corrosion may take place during storage if alcohol has washed protective oil films from internal components.

Filling Remote Oil Tank

Remove the filler cap and fill the tank with the specified oil. The oil tank capacity is 11.5 liters (3 US gallons). Replace the filler cap and tighten it securely.

IMPORTANT: Always make sure the oil tank caps are threaded on tight. An air leak will prevent oil flow to the engine.

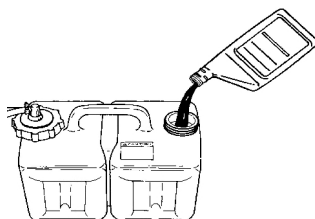

2723

Filling Engine-Mounted Oil Reservoir Tank

NOTE: Filling this tank is only necessary if the oil level should ever drop and the low oil warning system is activated.

1. Loosen the fill cap on the engine oil reservoir tank. Run the engine until all the air has been vented out of the oil reservoir tank and the tank is filled with oil to the point of overflow.

FUEL AND OIL

2. Tighten the fill cap.

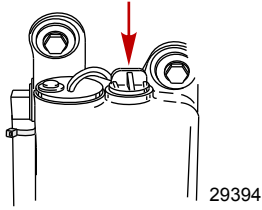

29394

FEATURES AND CONTROLS

Bilge Siphon

The Mercury Jet Drive incorporates an automatic bilge siphoning feature. The bilge siphon is working whenever the engine is running above idle speeds. Maximum performance of the bilge siphon is realized above 3000 RPM.

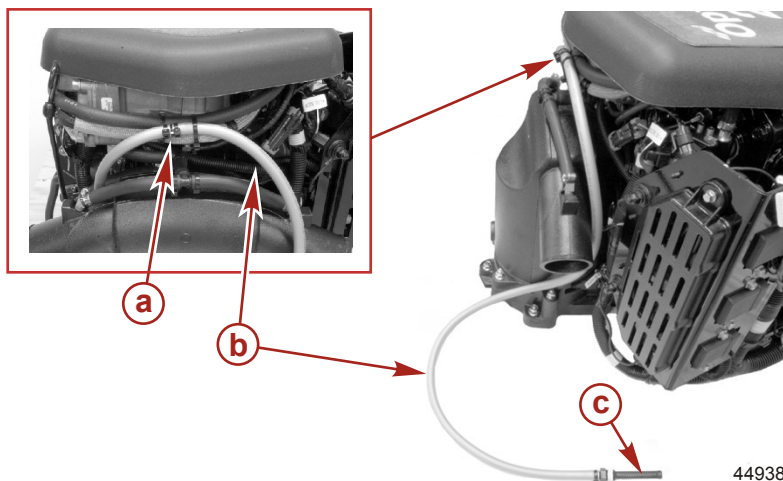

- a** - Siphon break
- b** - Bilge siphon hose
- c** - Bilge water pickup screen

Water exiting the jet pump nozzle creates a suction or vacuum in the hose attached to the nozzle. The hose is routed to and positioned in the bilge on the side of the jet tunnel.

The bilge siphon system incorporates a siphon break, which prevents water from siphoning back into the boat when the engine is turned off. This siphon break must be located at the highest point of the hose routing and must be above the waterline.

The siphon break requires periodic inspection to ensure proper operation. The 508 mm (0.020 in.) air hole must remain open and free from obstruction.

Warning System

WARNING HORN SIGNALS

When the key switch is turned to the "ON" position, the horn will turn on for a moment as a test to indicate the horn is working.

There are two types of warning horns to alert the operator of an active problem within the engine's operating system.

FEATURES AND CONTROLS

1. **Continuous six second beep:** Indicates a critical engine condition. Depending on the condition, the Engine Guardian system may engage and protect the engine by limiting power. You should return to port immediately and contact your servicing dealer.
2. **Intermittent short beeps for six seconds:** Indicates a noncritical engine condition. This condition does not require immediate attention. You may continue using your boat. Depending on the nature of the problem, however, the engine's power may be limited by the Engine Guardian system to protect the engine (refer to **Engine Guardian System** following). You should contact your servicing dealer at your earliest convenience.

It is important to note that in either of the above scenarios, the horn will only sound one time. If you key the engine off and restart it, the horn will sound again, one time, if the fault is still present. For visual display of the specific engine functions and additional engine data, refer to **SmartCraft Product** information, following.

A few of the noncritical conditions indicated by the intermittent short beeps for six seconds can be corrected by the operator. These operator correctable conditions are as follows:

- Water in the engine-mounted fuel filter. Refer to **Maintenance - Fuel System**.
- Cooling system (water pressure or engine temperature) problem. Stop the engine and check the water intake holes in the lower unit for obstruction.
- Low engine oil level. Refer to **Fuel and Oil - Filling Remote Oil Tank**.

ENGINE GUARDIAN SYSTEM

The Engine Guardian system monitors the critical sensors on the engine for any early indications of problems. Engine Guardian is functional whenever your engine is operating, so you never have to be concerned about whether or not the engine is protected. The system will respond to a problem by sounding the warning horn for six seconds or reducing engine power in order to provide engine protection.

If Engine Guardian has been activated, reduce the engine speed. Moving the throttle lever back to the idle position will reset the Engine Guardian system. If the Engine Guardian system has determined that the reset has not corrected the problem, Engine Guardian will remain activated, limiting the throttle. The problem must be identified and corrected before Engine Guardian will allow the engine to reach a normal operating speed.

OVERSPEED REV LIMIT

The overspeed rev limit is set at an RPM greater than the operating range. If the engine is operated at an RPM greater than or equal to the overspeed limit, the engine electronics will not allow the engine to maintain the power requested by the operator. Refer to **General Information - Specifications** to determine the RPM limit.

FEATURES AND CONTROLS

Upon reaching the rev limit, Engine Guardian will cut out the ignition to specific cylinders. If the operator does not reduce engine speed, Engine Guardian will cut out the ignition to all the cylinders. There is no audible warning while Engine Guardian overspeed limit is active.

To reset the Engine Guardian protection:

1. Completely reduce the throttle for three seconds.
2. Engage the throttle. If the engine does not respond, repeat step 1.

SMARTCRAFT PRODUCT

A Mercury SmartCraft System instrument package can be purchased for this outboard. A few of the functions the instrument package will display are engine RPM, coolant temperature, oil pressure, water pressure, battery voltage, fuel consumption, and engine operating hours.

The SmartCraft instrument package will also aid in Engine Guardian diagnostics. The SmartCraft Instrument package will display critical engine alarm data and potential problems.

OPERATION

Before Starting the Engine

NOTICE

Lack of oil pressure in the system can cause severe internal engine damage during start-up. Prime the oil injection pump on new or rebuilt engines or after performing maintenance on the oiling system.

Refer to **Priming the Oil Injection Pump** for instructions.

Prestarting Checklist

- Ensure that you are familiar with safe navigation, boating, and operating procedures.
- Ensure that an approved personal flotation device of suitable size is readily accessible for each person aboard. It is the law.
- Know your boat's maximum load capacity. Look at the boat capacity plate.
- Ensure there is an adequate fuel supply for the outing.
- Check the oil level in the oil reservoir. Add oil if necessary.
- Make sure that the boat drain plug is installed.
- Tell someone who is staying ashore where you are going and when you expect to return.
- Ensure that you are sober. Operating a boat while under the influence of alcohol or drugs is illegal.
- Know the characteristics of the waterways in which you will be boating: tides, currents, sand bars, rock, and other hazards.
- Perform the inspections and checks listed in the **Inspection and Maintenance Schedule**. Refer to the **Maintenance** section.
- Operate the bilge blower for at least five minutes to remove any explosive fumes from the engine compartment. If boat is not equipped with a bilge blower, open the engine hatch and leave open while starting the engine.
- Before launching, examine the jet drive pump inlet for obstructions, which may prevent pumping water.
- Check the steering for free operation.
- Check for debris around the rudder and reverse gate. Debris can jam or hinder operation.

OPERATION

Special Operating Instructions

OPERATING ON THE WATER

WARNING

Avoid serious injury or death due to the loss of boat control. A loss or reduction in water jet thrust will directly affect boat directional control, and may result in property damage, personal injury, or death. Use caution when maneuvering at high speeds in areas where debris (weeds, sand, gravel, etc.) could be picked up into the jet drive. The ability to take evasive action is dependent on sufficient water jet thrust to control the boat.

A jet drive boat has substantially different handling characteristics compared to a propeller driven boat. Experiment with the boat handling in open water at both high and low speeds.

Although jet drive applications do not pose some of the risks associated with exposed propeller driven systems, always keep the following in mind.

- The jet drive works by drawing water up through the bottom water intake and directs it to the rear for forward thrust. The Mercury Jet Drive has a steerable rudder that can direct the jet thrust to the right or left. If the engine stops or the water flow is blocked, this will stop the jet thrust causing the boat to slow to a stop. However, while slowing there will be no ability to steer as steering is dependent on jet thrust.
- Avoid the use of neutral or reverse while towing skiers, to minimize the chance that the ski rope will be drawn up into the jet pump intake. Turn the engine off when waiting for skiers. Ensure that the ski rope is clear before starting the engine.
- Avoid weed areas or traverse weed areas at high speeds. If unavoidable, keep the boat on plane until cleared of the weedy area.
- Avoid operating the jet drive in shallow water (less than 1 m [3 ft]) or where there is a noticeable amount of floating debris or weeds, especially when accelerating from idle. Any loose material such as sand, shells, stones, seaweed, grass, etc. can be drawn up by the pump and cause the following problems:
 - Overheated engine
 - Steering loss
 - Blockage of the pump
 - Loss of forward or reverse motion
 - Damage to the impeller, wear ring, or stator
 - Objects expelled from the pump at high speeds
- When beaching the boat, idle in forward to reach the beach. Turn the engine off without shifting to neutral. When leaving, push the boat into approximately 1 m (3 ft) of water. Start the engine and shift to forward. Avoid the use of neutral and reverse in shallow water.

OPERATION

- If the jet intake becomes fouled such that the boat cannot reach planing speeds, it may be possible to clear the obstruction as follows (perform this maneuver only in an area clear of obstacles and hazards as steering control will momentarily be lost):
 - a. Run the boat forward at maximum attainable nonplaning speed and turn left.
 - b. Turn the engine off while in forward. Turning the engine off while in forward allows water to flush backward through the jet and across the intake. As the boat coasts to a stop, water may flush away the obstruction.
- When the jet drive is in neutral, the drive impeller continues to rotate. However, the reverse gate is positioned so that some of the forward thrust is diverted to create reverse thrust. This approximate balancing of forward and reverse thrust will minimize any boat movement. Because the impeller is always rotating and creating thrust when the engine is running, the boat may tend to creep slowly forward or backward. This is normal for a direct-drive, jet-driven boat. Use caution whenever the engine is running.
- The jet drive is always drawing water into the housing when the engine is running. **Never** operate the jet drive with the grate removed from the water intake. Keep your hands, feet, hair, loose clothing, life jackets, etc. away from the water intake in the bottom of the boat. Never insert an object into the water intake or water outlet nozzle when the engine is running.

WARNING

Avoid injury resulting from contacting the rotating impeller or having hair, clothing, or loose objects drawn into the water intake and wrapping around the impeller shaft. Stay away from the water intake and never insert an object into the water intake or water outlet nozzle when the engine is running.

OPERATING IN FREEZING TEMPERATURES

If there is a chance of ice forming on the water, remove the boat from the water. If ice should form at the water level inside the jet drive, it will block water flow to the engine, causing possible damage.

OPERATING IN SALTWATER OR POLLUTED WATER

We recommend that you flush the internal water passages of your engine with fresh water after each time you operate in saltwater or polluted water. This will prevent a buildup of deposits from clogging the water passages. Refer to the flushing procedure in the **Maintenance** section.

Remove the boat and jet drive from the water when not in use.

OPERATION

Wash the exterior and interior of the jet drive with fresh water after each use. Each month, spray Quicksilver or Mercury Precision Corrosion Guard on external metal surfaces. Do not spray Corrosion Guard on the corrosion control anodes. Coating the anodes with Corrosion Guard will reduce the effectiveness of the anodes.

Engine Break-In Procedure

NOTE: Do not use premixed gas and oil in this engine. Use straight gasoline during engine break-in and after engine break-in.

The engine break-in procedure for your OptiMax engine is important to ensure proper performance and maximum life from the engine. The following break-in procedure allows the internal engine parts to wear evenly. Incorrect engine break-in can shorten the engine life.

The engine automatically receives extra oil during the first hours of operation. For most boaters, this extra oil mode will be complete in about ten hours.

First hour

- Allow the engine to warm up for 30–60 seconds.
- Avoid continuous operation at idle speed for more than 10 minutes.
- Run the engine the majority of time between 3000–4500 RPM, approximately three quarter throttle.
- Vary the engine speed; change the engine speed approximately every two minutes.
- Short bursts of full throttle for periods up to 10 seconds are acceptable.

Next three hours

- Change the engine speed every 10 minutes.

Starting the Engine

Before starting, read the **Prestarting Check List**, **Special Operating Instructions**, and **Engine Break-In Procedure**.

WARNING

Explosive fumes contained in the engine compartment can cause serious injury or death from fire or explosion. Before starting the engine, operate the bilge blower or vent the engine compartment for at least five minutes.

OPERATION

1. Before starting, operate the bilge blower for at least five minutes to remove explosive fumes from the engine compartment.

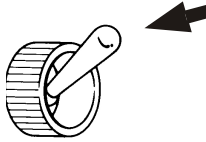

4640

NOTICE

Avoid damaging the engine and drive from overheating. Never start or run the power package without water circulating through the cooling system.

2. Do not start the jet drive unless water is supplied to the engine. Make sure the water intake is submerged. If using the flushing attachment, ensure that water is flowing through the engine at its maximum flow before starting. When using the flushing attachment, do not operate the engine above idle speeds.



5461

3. Ensure that the lanyard is properly connected to both the operator and the switch. Place the switch in the "RUN" position.



44353

OPERATION

- Shift the jet drive into neutral. Do not advance the throttle speed past idle for starting.

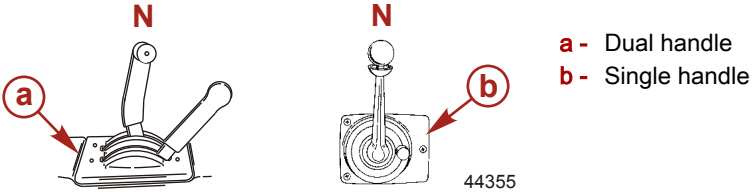

- For initial start of a new engine or for an engine that ran out of fuel or was drained of fuel, fill the fuel system as follows:
 - Turn the ignition key switch to the "ON" position for three seconds and then back to the "OFF" position for five seconds.
 - Continue this procedure five times to allow the electric fuel pump to fill the fuel system.
- Turn the ignition key to the "START" position. If the engine fails to start in ten seconds, return key to the "ON" position, wait 30 seconds, and try again.

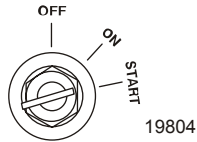

NOTE: The electronic starting system will automatically prime (choke) the engine and increase idle speed for starting.

Shifting

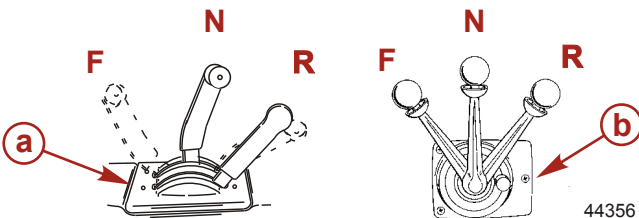

- The jet drive has three shift positions to provide operation: Forward (F), Neutral (N), Reverse (R).
 - Forward (F) - has all the water clearing the reverse gate for forward thrust and forward boat motion.

OPERATION

- b. Neutral (N) - has the reverse gate covering half the water outlet nozzle to distribute thrust both forward and backward. The drive impeller continues to rotate and the boat may tend to creep in one direction. This is normal for a direct-drive jet-driven boat. Use caution whenever the engine is running.
 - c. Reverse (R) - has the reverse gate covering the entire water outlet nozzle to divert the exiting water stream forward to reverse boat motion.
2. After shifting into forward or reverse, advance the throttle lever further to increase speed.

NOTE: Operators must practice the stopping maneuver to become familiar with jet drive handling.

3. To stop the boat normally, gradually reduce speed before shifting to the neutral position. Use caution when shifting and turning since some loss of steering control will result. Steering control is dependent on the thrust produced.

Stopping the Engine

1. Reduce the engine speed until the boat comes to a complete stop.
2. Shift the jet drive into neutral.
3. Turn the ignition key to the "OFF" position.

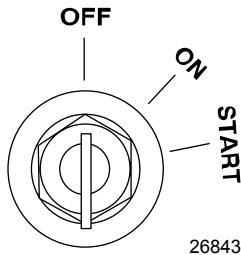

MAINTENANCE

Mercury Jet Drive Care

⚠ WARNING

Neglect or improper maintenance, repairs, or inspections of the power package can result in product damage or serious injury or death. Perform all procedures as described in this manual. If you are not familiar with proper maintenance or service procedures, consign the work to an authorized Mercury Marine dealer.

To ensure safety and retain dependability, keep your power package in the best operating condition by performing the periodic inspections and maintenance listed in the **Inspection and Maintenance Schedule**. Record maintenance performed in the **Maintenance Log** at the back of this book. Save all maintenance work orders and receipts.

Replacement Parts for Your Power Package

Mercury recommends using original Mercury Precision replacement parts and lubricants.

EPA Emissions Regulations

All new Mercury Jet Drives manufactured by Mercury Marine are certified to the United States Environmental Protection Agency, as conforming to the requirements of the regulations for the control of air pollution from new Mercury Jet Drive motors. This certification is contingent on certain adjustments set to factory standards. For this reason, the factory procedure for servicing the product must be strictly followed and, wherever practicable, returned to the original intent of the design. **Maintenance, replacement, or repair of the emission control devices and systems may be performed by any marine spark ignition (SI) engine repair establishment or individual.**

MAINTENANCE

EMISSION CERTIFICATION LABEL

An emission certification label, showing emission levels and engine specifications directly related to emissions, is placed on the engine at the time of manufacture.

MERCURY		EMISSION CONTROL INFORMATION	
THIS ENGINE CONFORMS TO [] CALIFORNIA AND U.S. EPA EMISSION REGULATIONS FOR SPARK IGNITION MARINE ENGINES			
REFER TO OWNERS MANUAL FOR REQUIRED MAINTENANCE, SPECIFICATIONS, AND ADJUSTMENTS			
IDLE SPEED (in gear): []		FAMILY: L []	
[] hp	[] L	HC+NOx:FEL: [] g/kWh	
[] kw		CO FEL: [] g/kWh	
[]	SPARK PLUG: []		[]
	GAP: []		[]
LOW PERM/HIGH PERM: []			

43210

- a - Idle speed
- b - Engine horsepower
- c - Engine displacement
- d - Engine power - kilowatts
- e - Date of manufacture
- f - Family number
- g - Regulated emission limit for the engine family
- h - Regulated emission limit for the engine family
- i - Recommended spark plug and gap
- j - Percent of fuel line permeation

OWNER RESPONSIBILITY

The owner/operator is required to have routine engine maintenance performed to maintain emission levels within prescribed certification standards.

The owner/operator is not to modify the engine in any manner that would alter the horsepower or allow emission levels to exceed their predetermined factory specifications.

Inspection and Maintenance Schedule

PRIOR TO EVERY USE

- Check that the lanyard stop switch stops the engine.
- Visually inspect the fuel system for deterioration or leaks.
- Check the engine compartment and use your nose to detect any fuel fumes.
- Check the throttle, shift, and steering system for binding or loose components.

AFTER EACH SALTWATER OR POLLUTED WATER USE

- Flush all internal passages with fresh water.

MAINTENANCE

- Wash the jet pump exterior with fresh water.

EVERY 10 HOURS OR ONCE A MONTH, WHICHEVER OCCURS FIRST

- Check the bilge siphon system. Refer to **Bilge Siphon Inspection**.
- Inspect the cable bellows for wear, rub marks, or leaks.
- Inspect the battery and connections. Refer to **Battery Inspection**.
- Check the tightness of bolts, nuts, and other fasteners.
- Check the exhaust hoses for holes or distortion due to overheating.

EVERY 50 HOURS OR ONCE A MONTH, WHICHEVER OCCURS FIRST

- Check the level and condition of drive housing and stator lubricant. Refer to **Drive Housing Lubricant** and **Stator Assembly Lubricant**.
- Check the corrosion control anodes. Replace if over 50% corroded. Refer to **Corrosion Control Anodes**.
- Check the tightness of bolts, nuts, and other fasteners.

EVERY 100 HOURS OR ONCE YEARLY, WHICHEVER OCCURS FIRST

- Replace the spark plugs at first 100 hours or first year. After that, inspect the spark plugs every 100 hours or once yearly. Replace the spark plugs as needed. Refer to **Spark Plug Inspection and Replacement**.
- Drain and replace the drive housing lubricant. Refer to **Drive Housing Lubricant**.
- Drain and replace the stator housing lubricant. Refer to **Stator Assembly Lubricant**.
- Remove the impeller and lubricate the impeller shaft with Quicksilver or Mercury Precision 2-4-C with PTFE to prevent the impeller from seizing to the shaft.
- Inspect the alternator belt. Refer to **Alternator Belt Inspection**.
- Lubricate the belt tensioner idler pulley. Refer to **Belt Tensioner Idler Pulley Lubrication**.
- Replace the engine fuel line filter. Refer to **Fuel System**.
- Replace the water separating fuel filter. Refer to **Fuel System**.
- Replace the compressor air intake filter. Refer to **Compressor Air Intake Filter**.

BEFORE PERIODS OF STORAGE

- Refer to **Storage**.

MAINTENANCE

Clearing A Clogged Water Intake

The hydro surge (weed) grate and cast aluminum grate are intended for general use. The rock grate is intended for use if operating the jet drive in rocky, shallow conditions.

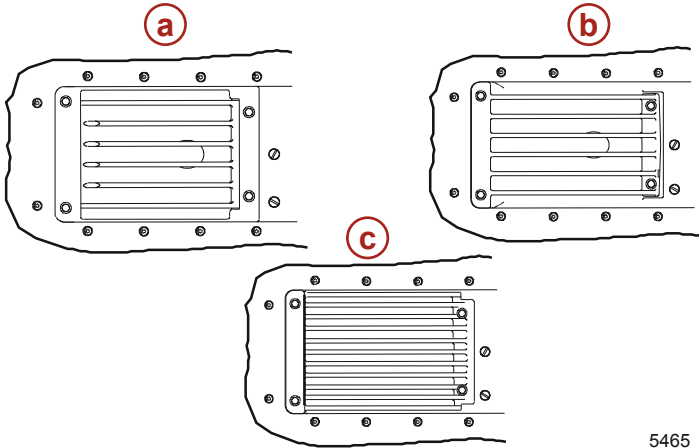

5465

- a - Hydro surge grate
- b - Cast aluminum grate
- c - Rock grate

MANUAL CLEARING

⚠ WARNING

Avoid injury resulting from contacting the rotating impeller or having hair, clothing, or loose objects drawn into the water intake and wrapping around the impeller shaft. Stay away from the water intake and never insert an object into the water intake or water outlet nozzle when the engine is running.

If weeds or debris clog the water intake, turn the engine off and completely clean out the blockage to return the unit to proper running order.

1. Turn off the engine and remove the key from the ignition switch. The pump impeller still spins and pumps water when the engine is running, even when in neutral.
2. Clean debris from the entire jet drive unit (water intake, impeller, and nozzle). If the jet drive cannot be easily cleaned, return the boat to the trailer or to a boat lift before performing any further work.
3. It may be necessary to remove the water intake grate from the bottom of the jet drive to clean debris from the water intake.
 - a. Remove the water intake grate by removing the four screws.
 - b. Install the water intake grate with the same four screws.

MAINTENANCE

- c. Apply Loctite 242 Threadlocker to the threads of the screws.
- d. Tighten the screws to the specified torque.

Tube Ref No.	Description	Where Used	Part No.
 66	Loctite 242 Threadlocker	Water intake grate screw threads	92-809821

Description	Nm	lb-in.	lb-ft
Front screws	23	–	17
Rear screws	8.5	75	–

IMPORTANT: Do not operate the jet drive without the water intake grate installed.

HYDRO SURGE GRATE

The hydro surge grate is spring-loaded. If the intake gets plugged, the pump suction will pull open the grate, and the water will push the blockage past the grate and clear the intake.

If operating the boat at slow speeds in weedy areas, the water intake grate can become plugged with weeds. A plugged grate causes the pump to cavitate during acceleration (over-revving without thrusting the boat).

If the grate becomes plugged:

1. Slowly advance the throttle to get the boat up on plane, making sure not to cavitate the pump.
2. Continue to advance the throttle until the boat is running at top speed. The force of the water should clear the pump of any remaining weeds.

Fuel System

▲ WARNING

Fuel is flammable and explosive. Ensure that the key switch is off and the lanyard is positioned so that the engine cannot start. Do not smoke or allow sources of spark or open flame in the area while servicing. Keep the work area well ventilated and avoid prolonged exposure to vapors. Always check for leaks before attempting to start the engine, and wipe up any spilled fuel immediately.

Before servicing any part of the fuel system, stop the engine and disconnect the battery. Drain the fuel system completely. Use an approved container to collect and store fuel. Wipe up any spillage immediately. Material used to contain spillage must be disposed of in an approved receptacle. Any fuel system service must be performed in a well-ventilated area. Inspect any completed service work for signs of fuel leakage.

MAINTENANCE

FUEL LINE INSPECTION

Inspect the fuel line for cracks, swelling, leaks, hardness, or other signs of deterioration or damage. If any of these conditions are found, the fuel line must be replaced.

FUEL LINE FILTER

Replace the fuel filter once a season or every 100 hours of use.

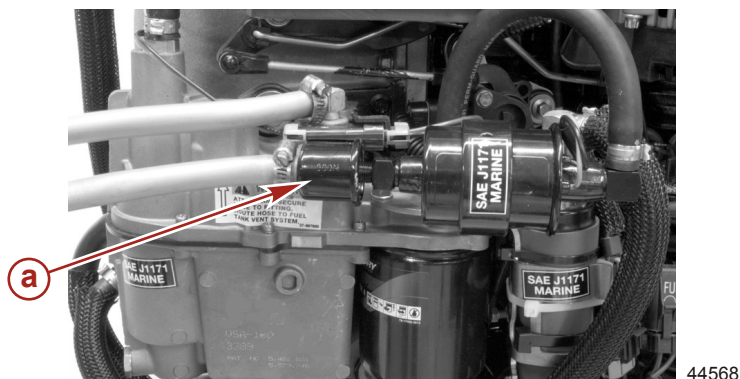

a - Fuel filter

IMPORTANT: Visually inspect for fuel leakage from the filter connections.

WATER SEPARATING FUEL FILTER

This filter removes moisture and debris from the fuel. If the filter becomes filled with water, the water can be removed. If the filter becomes plugged with debris, replace the filter. The warning system engages when water in the fuel filter reaches the full level. Refer to **Warning System** in **Features and Controls**.

Refer to the **Inspection and Maintenance Schedule** for the proper maintenance interval.

Remove and replace the filter as follows:

1. Turn the ignition key switch to the "OFF" position.

MAINTENANCE

2. Disconnect the wire from the bottom of the filter. Remove the filter (a) by turning the filter in the direction of the arrow (clockwise). Tip the filter to drain the fluid into a suitable container.

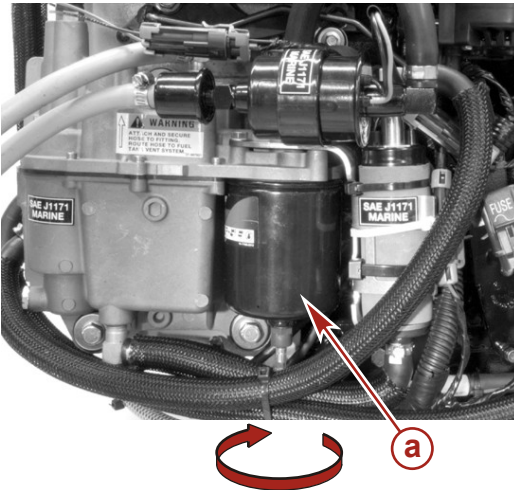

a - Water separating fuel filter

3. Lubricate the sealing ring on the filter with oil. Thread the filter into place. Tighten it securely by hand. Connect the wire to the filter.

Fuses

IMPORTANT: Always carry spare 5, 15, and 20-amp fuses.

The electrical wiring circuits on the engine are protected from overload by fuses in the wiring. If a fuse is open, try to locate and correct the cause of the overload. If the cause is not found, the fuse may open again.

1. Open the fuse holder and look at the silver colored band inside the fuse. If the band is broken, replace the fuse.
2. Replace the fuse with a new fuse with the same rating.

MAINTENANCE

The fuses and circuits are identified as follows:

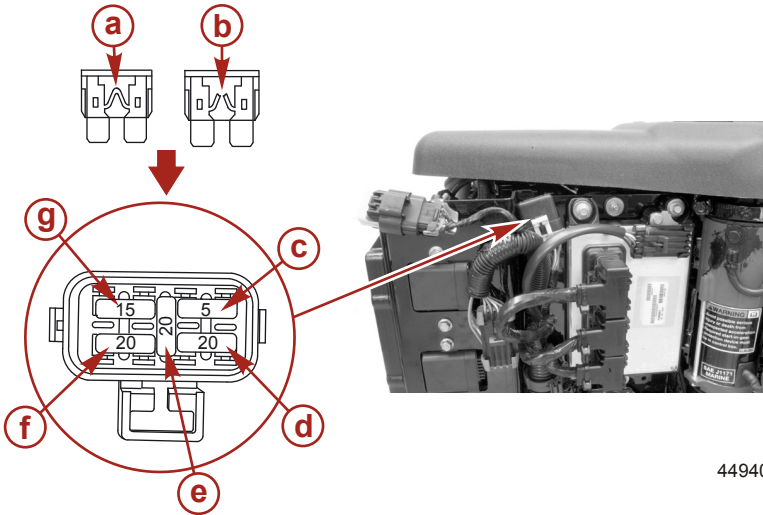

44940

- a** - Good fuse
- b** - Open (blown) fuse
- c** - SmartCraft data bus circuit - 5-amp fuse
- d** - Ignition system circuit - 20-amp fuse
- e** - Spare fuse
- f** - Electric fuel pump (VST), ECM driver power, and oil pump circuit - 20-amp fuse
- g** - Main power relay - 15-amp fuse

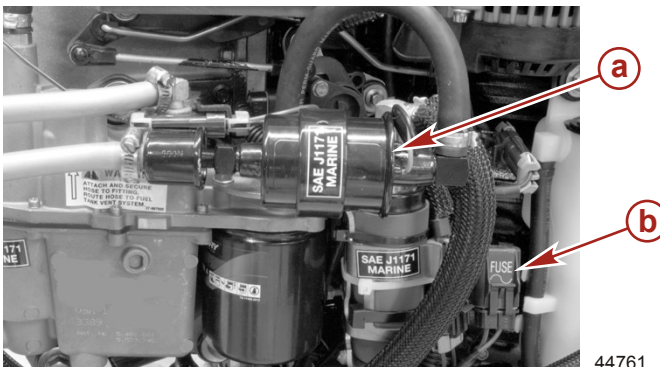

44761

- a** - Lift pump
- b** - Lift pump circuit - 5-amp fuse

MAINTENANCE

Corrosion Control Anodes

NOTICE

Anodes made of insufficiently pure aluminum alloys may not adequately protect critical drive components from corrosion. We recommend using anodes sold through Mercury Precision Parts only.

This model has three corrosion control anodes: One on the bottom of the nozzle, one on the reverse gate, and one under the rudder. Anodes help protect the Mercury Jet Drive against galvanic corrosion by sacrificing their metal to be slowly eroded instead of the Mercury Jet Drive metals.

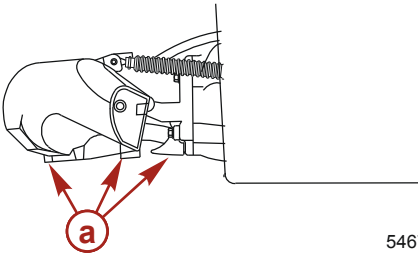

a - Anodes

5467

All anodes require periodic inspection, especially in saltwater. Refer to the **Inspection and Maintenance Schedule**. Replace any anodes before they are 50% corroded. Never paint or apply protective coating on the anode, as effectiveness of the anode will be reduced.

Battery Inspection

The battery should be inspected periodically to ensure proper engine starting capability.

IMPORTANT: Read the safety and maintenance instructions that accompany your battery.

1. Turn off the engine before servicing the battery.
2. Ensure that the battery is secure against movement.
3. Battery cable terminals should be clean, tight, and correctly installed. Battery cables must be connected with the correct polarity (positive to positive and negative to negative).
4. Ensure that the battery is equipped with a nonconductive shield to prevent accidental shorting of battery terminals.

MAINTENANCE

Spark Plug Inspection and Replacement

⚠ WARNING

Damaged spark plug boots may emit sparks that can ignite fuel vapors under the engine cowl, resulting in serious injury or death from a fire or explosion. To avoid damaging the spark plug boots, do not use any sharp object or metal tool to remove the spark plug boots.

1. Loosen the hoses from the expansion chamber. Remove the six nuts that secure the expansion chamber. Remove the expansion chamber.

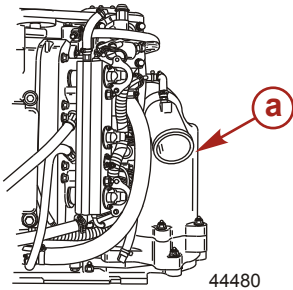

a - Expansion chamber

2. Open J-clips to move fuel/air lines out of the way.
3. Remove the spark plug leads by twisting the rubber boots while pulling them off the spark plugs.

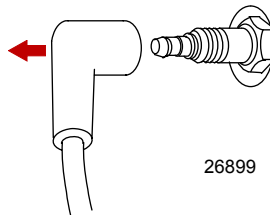

4. Remove the spark plugs. Replace the spark plug if the electrode is worn; the insulator is rough, cracked, broken, or blistered; or if the precious metal is not visible on the spark plug electrode.

MAINTENANCE

IMPORTANT: The color of the plug may not accurately reflect its condition. To accurately diagnose a faulty plug, inspect the precious metal on the plug's electrode. If no precious metal is visible, replace the plug.

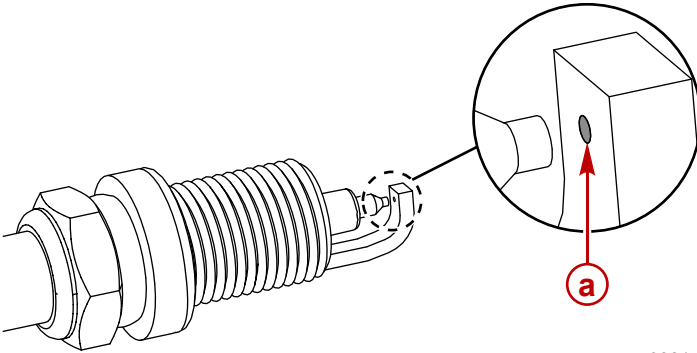

9381

a - Precious metal

5. Set the spark plug gap. Refer to **General Information - Specifications**.

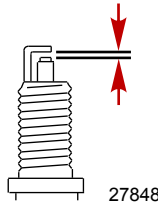

- Ensure that all of the spark plugs are properly gapped prior to installation.
 - Measure the gap with a feeler gauge or pin gauge. Never use a wedge-type gap checking tool to inspect or to adjust the gap.
 - If an adjustment is necessary, do not pry or apply any force on the center electrode. This is critical with any type of spark plug that has a wear surface, such as platinum or iridium added to either the ground electrode or the center electrode.
 - When it is necessary to widen the gap, use a tool that only pulls back on the ground electrode without touching the center electrode, the porcelain, or the wear portion of the ground electrode.
 - When it is necessary to close the gap, gently tap the plug ground electrode on a hard surface.
6. Before installing spark plugs, clean off any dirt on the spark plug seats. Install the plugs finger-tight and then tighten an additional 1/4 turn or tighten to the specified torque.

MAINTENANCE

Description	Nm	lb-in.	lb-ft
Spark plug	27	–	20

7. Inspect the expansion chamber gasket on the adapter plate. Do not remove the gasket from the adapter plate. Replace if damaged.
8. Install the expansion chamber. Tighten the mounting nuts to the specified torque. Install the hoses to the expansion chamber and secure with clamps.

Description	Nm	lb-in.	lb-ft
Expansion chamber mounting nuts	27	–	20

9. Inspect the exhaust system for leaks.

Flywheel Cover Removal and Installation

REMOVAL

1. Detach the retaining strap.
2. Remove the cover by lifting off from the back of the engine.

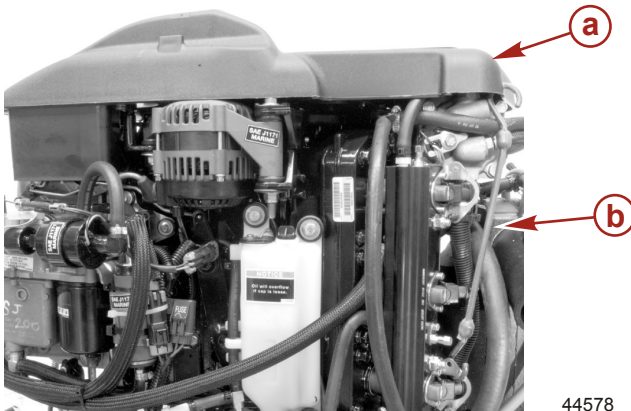

- a** - Flywheel cover
- b** - Retaining strap

INSTALLATION

1. Lower the cover opening onto the air plenum intake flange. Tilt the cover side to side until the cover slides down onto the intake flange.

MAINTENANCE

2. Push the cover down onto the alignment pins and onto the air intake tube for the air compressor.

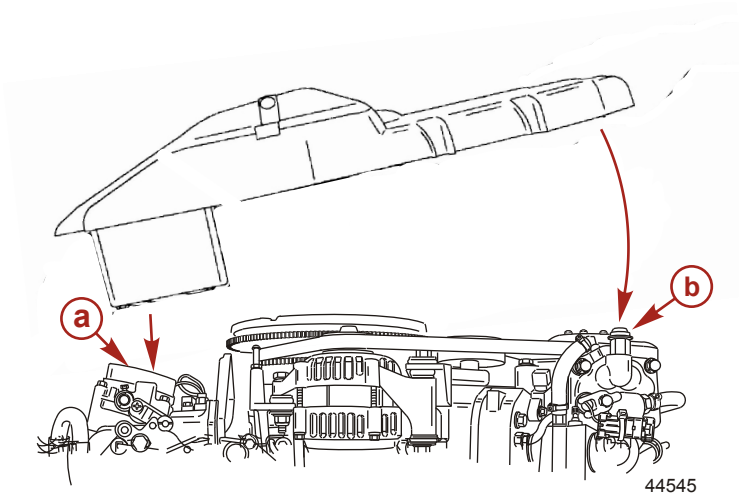

- a** - Air plenum intake flange
- b** - Air intake tube for the air compressor

3. Attach the retaining strap to the cover.

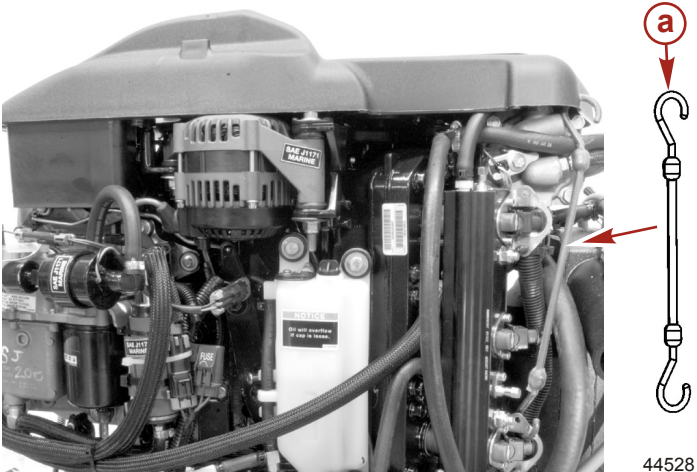

- a** - Retaining strap

MAINTENANCE

Alternator Belt Inspection

Inspect the alternator belt and have it replaced by an authorized dealer if any of the following conditions are found:

- Cracks or deterioration in the rubber portion of the belt
- Belt surfaces rough or uneven
- Signs of wear on the edges or outer surfaces of the belt

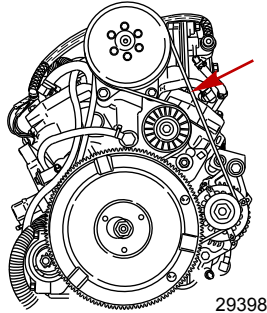

Compressor Air Intake Filter

The filter should be changed every 100 hours of operation, or once a season.

IMPORTANT: Never run the engine without the air filter.

REMOVAL

1. Remove the flywheel cover from the engine.
2. Snap the retainer out of the cover and remove the filter.

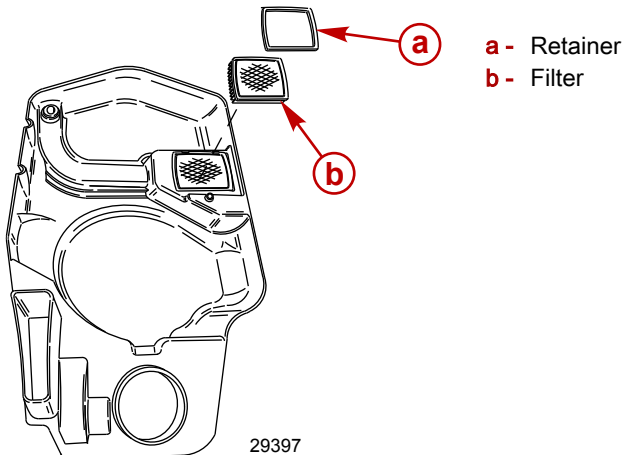

INSTALLATION

1. Install the filter into the cover.

MAINTENANCE

2. Secure the filter with the retainer.

Belt Tensioner Idler Pulley Lubrication

Lubricate through the fitting with 2-4-C with PTFE.

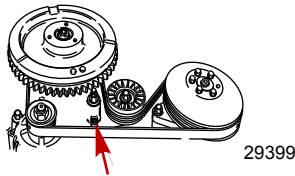

Tube Ref No.	Description	Where Used	Part No.
 95	2-4-C with PTFE	Tensioner pulley grease fitting	92-802859A 1

Flushing the Cooling System

Flushing the cooling system is essential after each use in saltwater, after the boat has run aground, or if the warning horn sounds due to an overheated engine.

NOTICE

Avoid damaging the engine and drive from overheating. Never start or run the power package without water circulating through the cooling system.

NOTICE

Flushing the cooling system with the bow down will result in water ingestion, which will damage the engine. When flushing the cooling system, the boat must be level or bow-up (maximum of 20 degrees). Engine damage caused by improper flushing of the cooling system is not covered by warranty.

1. Ensure that the engine is off.
2. Position the boat so that it is level or the bow is up by no more than 20°. Flushing the engine with the boat in any position outside of this range can damage the engine and void your warranty.

MAINTENANCE

3. Remove the cap from the boat's flush adapter. The adapter may be mounted to the hull or in the engine compartment.

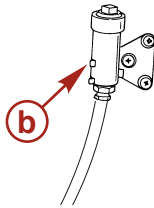
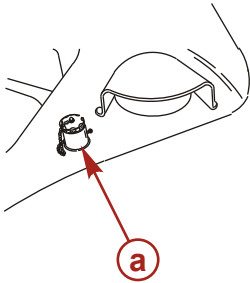

- a - Flushing attachment (hull mount)
- b - Flushing attachment (engine compartment mount)

5469

IMPORTANT: Do not run the engine above idle when flushing.

4. Turn the water on full. Start the engine and let it run for at least 10 minutes to flush the engine block.

NOTE: An insufficient flow of water to the engine may cause the engine to overheat. If the warning horn sounds, stop the engine immediately and allow the engine to cool.

5. Stop the engine, turn off the water, and remove the water hose from the flush adapter. Install the cap and tighten it securely.
6. Rinse the outer surfaces of the water outlet nozzle with water.

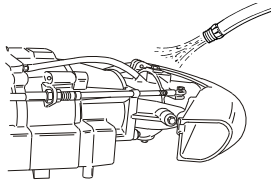

5470

MAINTENANCE

Drive Housing Lubricant

DRAINING LUBRICANT

NOTE: When draining the drive housing lubricant, visually check for water in the lubricant. It may have settled to the bottom and will drain before the lubricant or it may have mixed with the lubricant, giving it a milky color. In either case, have the drive housing checked by your authorized Mercury Marine dealer. Water in the lubricant can cause premature gear or bearing failure or, in freezing weather, damage to the drive housing.

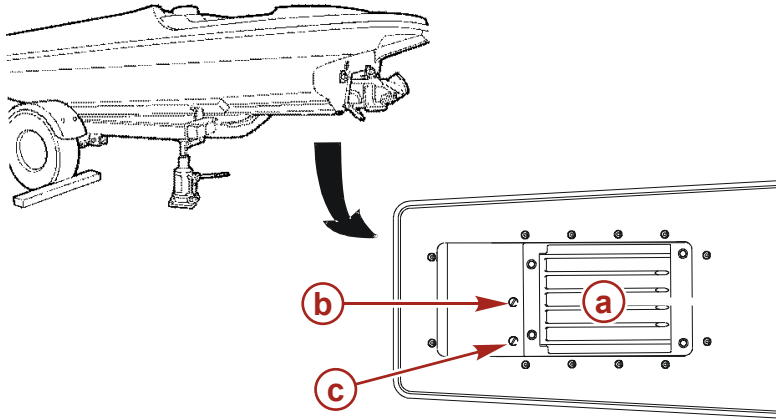

5472

- a** - Drive housing (bottom view)
- b** - Fill/drain screw
- c** - Vent screw

1. Place a drain pan below the drive.
2. Remove the fill/drain screw.
3. Remove the vent screw to drain the lubricant.

ADDING LUBRICANT

Fluid Type	Capacity
High Performance Gear Lube	725 cc (24 oz)

1. Insert the nozzle of the gear lubricant tube in the drive housing's fill/drain hole.
2. Add lubricant to the point of overflow.
3. Install the vent screw. Ensure that the screw gasket is in place.
4. Remove the nozzle of the tube and install the fill/drain screw with the gasket.

MAINTENANCE

Stator Assembly Lubricant

DRAINING LUBRICANT

NOTE: When draining stator lubricant, check for water in the lubricant. It may have settled to the bottom and will drain before the lubricant, or it may have mixed with the lubricant giving it a milky color. In either case, have the stator checked by your authorized Mercury Marine dealer. Water in the lubricant can cause premature bearing failure or, in freezing weather, damage to the stator.

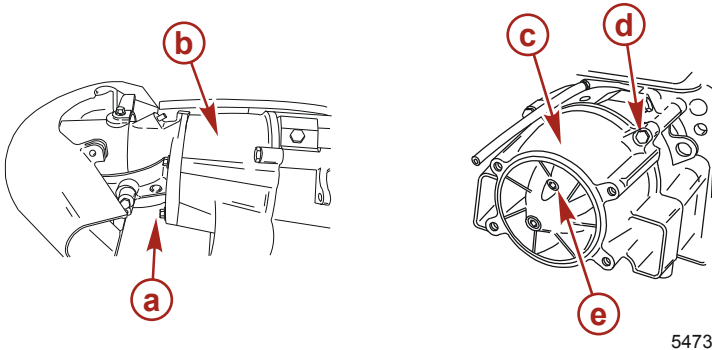

- a** - Screws securing nozzle assembly (4)
- b** - Nozzle assembly
- c** - Stator assembly
- d** - Screws securing stator assembly (4)
- e** - Fill hole and plug

1. Disconnect the shift and steering cables from the reverse gate and rudder. Be careful not to change adjustments.
2. Remove the four screws securing the nozzle assembly to the stator.
3. Remove the nozzle.
4. Remove the four screws securing the stator assembly to the drive housing and the two screws to the ride plate.
5. Remove the stator.
6. Remove the plug from the fill hole at the rear of the stator.
7. Tip the stator forward to drain the lubricant initially.
8. Tip the stator to drain the remaining lubricant out the fill hole.
9. Install the stator onto the pump. Be careful when sliding the shaft past the seals to prevent damage to the seals. Apply Loctite 242 Threadlocker to the four stator bolts and the two ride plate screws. Tighten the screws to the specified torque.

MAINTENANCE

Tube Ref No.	Description	Where Used	Part No.
 66	Loctite 242 Threadlocker	Stator bolts and ride plate screws	92-809821

Description	Nm	lb-in.	lb-ft
Stator bolts	47	–	35
Ride plate screws	8.5	75	–

ADDING OR REFILLING LUBRICANT

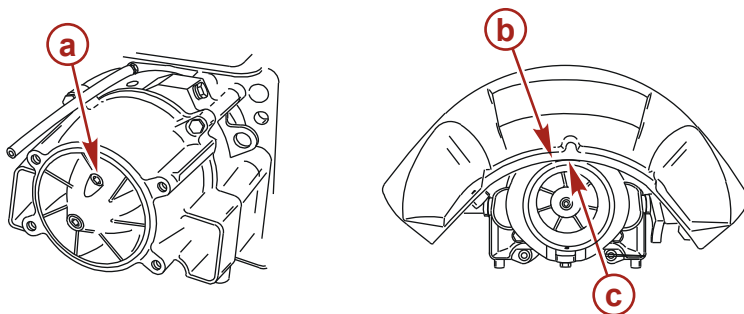

5474

- a** - Fill hole
- b** - Reverse gate (bottom edge)
- c** - Rudder (outside diameter)

Fluid Type	Capacity
High Performance Gear Lube	562 ml (19 fl oz)

1. Insert the nozzle of the lubricant tube in the fill hole on the stator.
2. Add lubricant until it appears at the hole.
3. Install the plug.
4. Apply Loctite 271 Threadlocker to four nozzle screws. Install the nozzle assembly and anode. Secure with four screws. Tighten the screws to the specified torque.

Tube Ref No.	Description	Where Used	Part No.
 7	Loctite 271 Threadlocker	Nozzle screws	92-809819

MAINTENANCE

Description	Nm	lb-in.	lb-ft
Nozzle screws	47	–	35

5. Connect the steering and shift cables.
6. Shift and steer the unit through the entire range and check for any binding or stiffness. Correct adjustments as necessary.
7. Shift to forward position and check that the reverse gate is not preloaded. You should be able to slightly rock the reverse gate up and down. Excessive play requires shift cable adjustment.
8. Check that the bottom edge of the reverse gate is above the outside diameter of the rudder. If the reverse gate is below the outer diameter of the rudder, do not operate the boat. See an authorized Mercury Marine dealer for proper adjustment.

IMPORTANT: Adjust the shift cable so that the reverse gate does not interfere with water flow coming out of the rudder. If the reverse gate is hanging in the water flow, a strong vibration may be felt in the control box and failure of the forward stop or other components will result.

Bilge Siphon Inspection

Inspect the bilge siphon system at periodic intervals to ensure maximum performance.

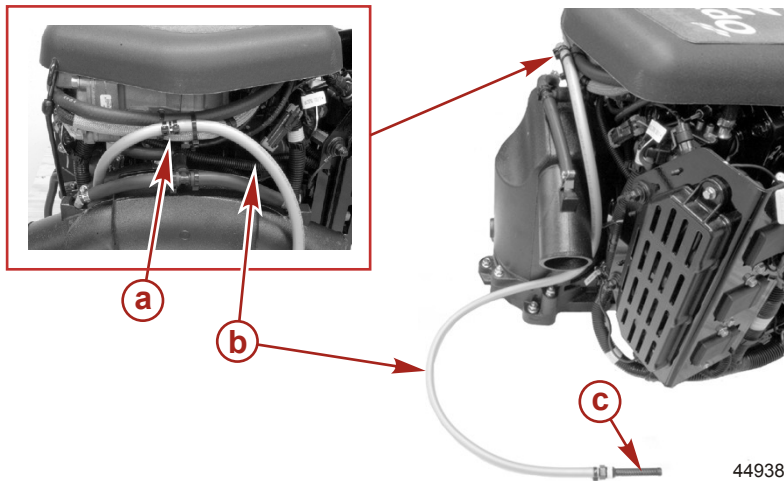

- a** - Siphon break
- b** - Bilge hose
- c** - Bilge water pickup screen

1. Inspect the pickup screen for foreign material. Clean if necessary.

MAINTENANCE

2. Inspect the hole in the siphon break for blockage. Clean with a small wire if necessary.
3. Ensure that the siphon break is secured above the waterline.

Submerged Power Package

A submerged power package requires prompt service by an authorized dealer after recovery. This immediate attention is necessary once the engine is exposed to the atmosphere to minimize internal corrosion damage to the engine.

STORAGE

Storage Preparation

The major consideration in preparing your Mercury Jet Drive for storage is to protect it from rust, corrosion, and damage caused by freezing of trapped water.

The following storage procedures should be followed to prepare your Mercury Jet Drive for out of season storage or prolonged storage (two months or longer).

NOTICE

Without sufficient cooling water, the engine, the water pump, and other components will overheat and suffer damage. Provide a sufficient supply of water to the water inlets during operation.

FUEL SYSTEM

IMPORTANT: Gasoline containing alcohol (ethanol or methanol) can cause a formation of acid during storage and can damage the fuel system. If the gasoline being used contains alcohol, it is advisable to drain as much of the remaining gasoline as possible from the fuel tank, remote fuel line, and engine fuel system.

The most effective method for storage preparation is to add the recommended amount of Mercury Precision Quickstor Fuel Stabilizer and Mercury Precision Quickleen products to the fuel tank as described on their containers. Adding fuel stabilizer will help prevent the formation of varnish and gum in the gasoline. The Mercury Precision Quickleen product will help clean and lubricate the fuel injectors.

1. Portable fuel tank - Pour the required amount of gasoline stabilizer (follow the instructions on the container) into the fuel tank. Tip the fuel tank back and forth to mix the stabilizer with the fuel.
2. Permanently installed fuel tank - Pour the required amount of gasoline stabilizer (follow the instructions on the container) into a separate container and mix it with approximately one liter (one quart) of gasoline. Pour this mixture into the fuel tank.
3. Remove the water separating fuel filter from the engine. Empty the fuel into a suitable container and discard the filter properly.
4. Premix the following in a container:
 - 8.0 ml (0.27 oz) of Mercury Precision Quickleen
 - 8.0 ml (0.27 oz) of Mercury Precision Quickstor
5. Pour this mixture into a new water separating fuel filter. Install the fuel filter.
6. Fill the fuel system as follows:
 - a. Turn the ignition key switch to the "ON" position for three seconds, and then back to the "OFF" position for five seconds.
 - b. Continue this procedure five times to allow the electric fuel pump to fill the fuel system.

STORAGE

7. Using the flushing adapter, start the engine and allow the engine to run at idle speed for 10 minutes to allow the treated fuel to fill the fuel system.

Protecting Internal Engine Components

NOTE: Make sure that the fuel system has been prepared for storage. Refer to **Fuel System**, preceding.

IMPORTANT: Refer to **Spark Plug Inspection and Replacement for the correct procedure for removing spark plug leads.**

1. Remove the spark plugs and add approximately 30 ml (1 fl oz) of engine oil into each spark plug hole.
2. Rotate the flywheel manually several times to distribute the oil in the cylinders.
3. Install the spark plugs.

TROUBLESHOOTING

Starter Motor Will Not Crank the Engine

POSSIBLE CAUSES

- 20-amp fuse in the starting circuit is open. Refer to **Maintenance**.
- Jet drive is not shifted into the neutral position.
- Battery is weak or the battery connections are loose or corroded.
- Ignition key switch failed.
- Wiring or an electrical connection is faulty.
- Starter motor solenoid or the slave solenoid failed.

Engine Will Not Start

POSSIBLE CAUSES

- Lanyard stop switch is not in the "RUN" position.
- Battery is not fully charged.
- Incorrect starting procedure was used. Refer to **Operation**.
- Fuel is old or contaminated.
- Fuel is not reaching the engine.
 - Fuel tank is empty.
 - Fuel tank vent is not open or is restricted.
 - Fuel line is disconnected or kinked.
 - Fuel filter is obstructed. Refer to **Maintenance**.
 - Fuel pump failed.
 - Fuel tank filter is obstructed.
- 20-amp fuse is open. Check the fuses. Refer to **Maintenance**.
- Threaded connection of an air hose is loose.
- Ignition system component failed.
- Spark plugs are fouled or defective. Refer to **Maintenance**.

Engine Runs Erratically

POSSIBLE CAUSES

- Spark plugs are fouled or defective. Refer to **Maintenance**.
- System setup or adjustments were done incorrectly.
- Fuel to the engine is being restricted.
 - Engine fuel filter is obstructed. Refer to **Maintenance**.
 - Fuel tank filter is obstructed.
 - Antisiphon valve on built-in fuel tank is stuck.
 - Fuel line is kinked or pinched.
 - Injector is plugged.

TROUBLESHOOTING

- Threaded connection of an air hose is loose.
- Fuel pump failed.
- Ignition system component failed.

Performance Loss at Normal RPM

POSSIBLE CAUSES

- Boat overloaded or load improperly distributed.
- Excessive water in bilge.
- Boat bottom is dirty or damaged.

Performance Loss at Wide-Open Throttle

POSSIBLE CAUSES OF LOW RPM (USUALLY ENGINE RELATED)

- Throttle is not fully open.
- Exhaust system is blocked.
- Ignition system has a problem.
- Spark plug is fouled or an injector failed.
- Air compressor inlet is blocked.

POSSIBLE CAUSES OF HIGH RPM (USUALLY PUMP RELATED)

- Impeller is damaged.
- Impeller or wear ring is worn.
- Impeller, inlet, or stator is fouled.
- Ride plate seal has a leak.

Battery Will Not Hold Charge

POSSIBLE CAUSES

- Battery connections are loose or corroded.
- Low electrolyte level in battery.
- Worn out or inefficient battery.
- Excessive use of electrical accessories.
- Defective rectifier, alternator, or voltage regulator.

OWNER SERVICE ASSISTANCE

Local Repair Service

Always return your outboard to your local authorized dealer should the need for service arise. Only he has the factory trained mechanics, knowledge, special tools, equipment, and genuine parts and accessories to properly service your engine should the need occur. He knows your engine best.

Service Away from Home

If you are away from your local dealer and the need arises for service, contact the nearest authorized dealer. Refer to the Yellow Pages of the telephone directory. If, for any reason, you cannot obtain service, contact the nearest Mercury Marine Service Office.

Stolen Power Package

If your power package is stolen, immediately advise the local authorities and Mercury Marine of the model and serial numbers and to whom the recovery is to be reported. This information is maintained in a database at Mercury Marine to aid authorities and dealers in the recovery of stolen power packages.

Attention Required After Submersion

1. Before recovery, contact an authorized Mercury dealer.
2. After recovery, immediate service by an authorized Mercury dealer is required to reduce the possibility of serious engine damage.

Replacement Service Parts

WARNING

Avoid fire or explosion hazard. Electrical, ignition, and fuel system components on Mercury Marine products comply with federal and international standards to minimize risk of fire or explosion. Do not use replacement electrical or fuel system components that do not comply with these standards. When servicing the electrical and fuel systems, properly install and tighten all components.

Marine engines are expected to operate at or near full throttle for most of their lives. They are also expected to operate in both fresh and saltwater environments. These conditions require numerous special parts.

Parts and Accessories Inquiries

All inquiries concerning genuine replacement parts and accessories should be directed to your local authorized dealer. The dealer has the necessary information to order parts and accessories for you. When inquiring about parts and accessories, the dealer requires the model and serial number to order the correct parts.

OWNER SERVICE ASSISTANCE

Resolving a Problem

Satisfaction with your Mercury product is important to your dealer and to us. If you ever have a problem, question, or concern about your power package, contact your dealer or any authorized Mercury dealership. If you need additional assistance:

1. Talk with the dealership's sales manager or service manager. Contact the owner of the dealership if the sales manager and service manager have been unable to resolve the problem.
2. If your question, concern, or problem cannot be resolved by your dealership, please contact the Mercury Marine Service Office for assistance. Mercury Marine will work with you and your dealership to resolve all problems.

The following information will be needed by the Customer Service:

- Your name and address
- Your daytime telephone number
- The model and serial numbers of your power package
- The name and address of your dealership
- The nature of the problem

Contact Information for Mercury Marine Customer Service

For assistance, call, fax, or write to the geographic office in your area. Please include your daytime telephone number with mail and fax correspondence.

United States, Canada		
Telephone	English +1 920 929 5040 Français +1 905 636 4751	Mercury Marine W6250 Pioneer Road P.O. Box 1939 Fond du Lac, WI 54936-1939
Fax	English +1 920 929 5893 Français +1 905 636 1704	
Website	www.mercurymarine.com	

Australia, Pacific		
Telephone	+61 3 9791 5822	Brunswick Asia Pacific Group 41-71 Bessemer Drive Dandenong South, Victoria 3175 Australia
Fax	+61 3 9706 7228	

Europe, Middle East, Africa		
Telephone	+32 87 32 32 11	Brunswick Marine Europe Parc Industriel de Petit-Rechain B-4800 Verviers, Belgium
Fax	+32 87 31 19 65	

OWNER SERVICE ASSISTANCE

Mexico, Central America, South America, Caribbean		
Telephone	+1 954 744 3500	Mercury Marine 11650 Interchange Circle North Miramar, FL 33025 U.S.A.
Fax	+1 954 744 3535	

Japan		
Telephone	+072 233 8888	Kisaka Co., Ltd. 4-130 Kannabecho, Sakai-ku Sakai-shi, Osaka 590-0984, Japan
Fax	+072 233 8833	

Asia, Singapore		
Telephone	+65 65466160	Brunswick Asia Pacific Group T/A Mercury Marine Singapore Pte Ltd 29 Loyang Drive Singapore, 508944
Fax	+65 65467789	

Ordering Literature

Before ordering literature, have the following information about your power package available:

Model		Serial Number	
Horsepower		Year	

UNITED STATES AND CANADA

For additional literature for your Mercury Marine power package, contact your nearest Mercury Marine dealer or contact:

Mercury Marine		
Telephone	Fax	Mail
(920) 929-5110 (USA only)	(920) 929-4894 (USA only)	Mercury Marine Attn: Publications Department P.O. Box 1939 Fond du Lac, WI 54935-1939

OUTSIDE THE UNITED STATES AND CANADA

Contact your nearest Mercury Marine authorized service center to order additional literature that is available for your particular power package.

OWNER SERVICE ASSISTANCE

Submit the following order form with payment to:	Mercury Marine Attn: Publications Department W6250 Pioneer Road P.O. Box 1939 Fond du Lac, WI 54936-1939
--	--

Ship To: (Copy this form and print or type—This is your shipping label)

Name	
Address	
City, State, Province	
ZIP or postal code	
Country	

Quantity	Item	Stock Number	Price	Total
			.	.
			.	.
			.	.
			.	.
			.	.
			Total Due	.

